

CMS15687 HFX Drill Head Chain Tensioner KIT

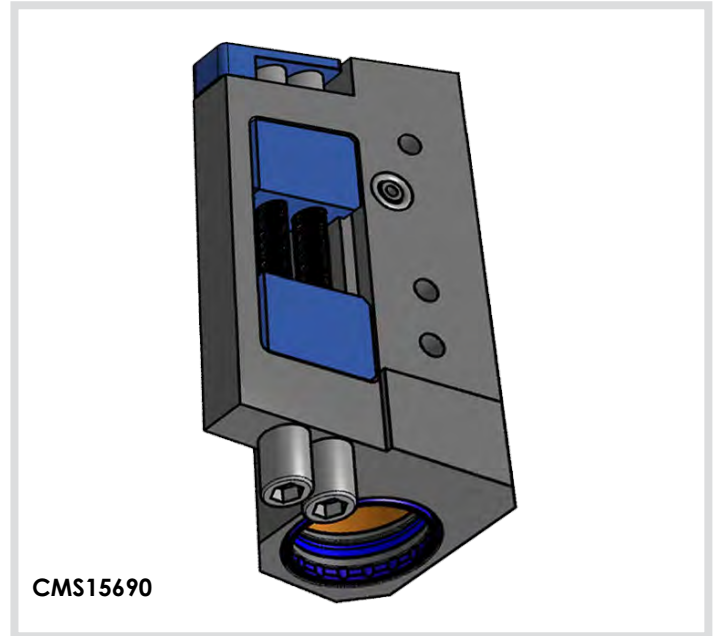
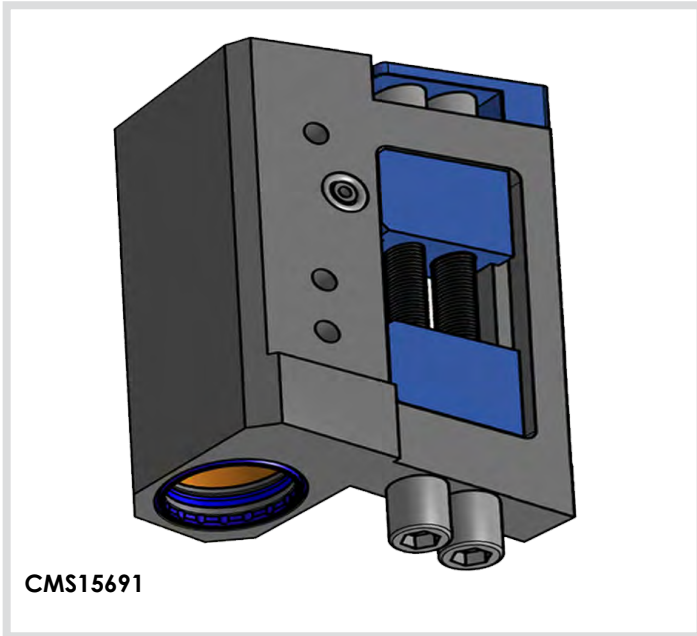

CMS15687 is a chain tensioner and TSRU Drill head retainer assembly for typical HFX drill rigs, used to mount the TSRU to the feed cylinder slides.

One CMS15687 assembly is required for each Drill.

CMS15687 is typically used in conjunction with CMS15688 HFX TSRU Standoff Plate.

CMS15687 kit includes one each of CMS15691 + CMS15690 and all necessary seals, wear-strips and O rings.

Replacement seals wear-strips and O rings are available as a kit CMS15692

CMS15691 HFX Drill Head Chain Tensioner Left Hand Side

CMS15690 HFX Drill Head Chain Tensioner Right Hand Side

Specifications

- Weight: 5.39kg

All consumable spares are available in CMS15692 Seal Kit containing:

- 4 x Rod Seal 45mm PU
- 4 x Wiper Seal 45mm PU
- 4 x Bearing Strip 45x50x30 Glass Filled Nylon
- 2 x O-Ring BS206 NBR

CMS15687 HFX Drill Head Chain Tensioner KIT

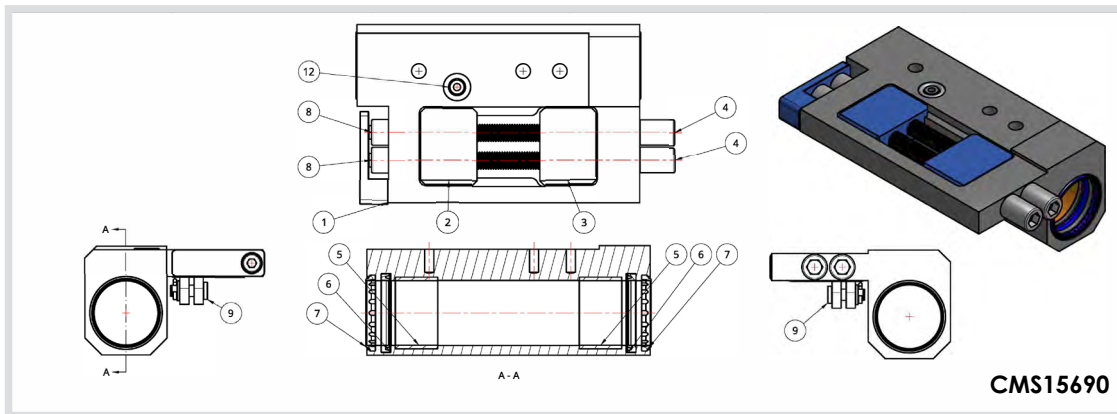

CMS15690

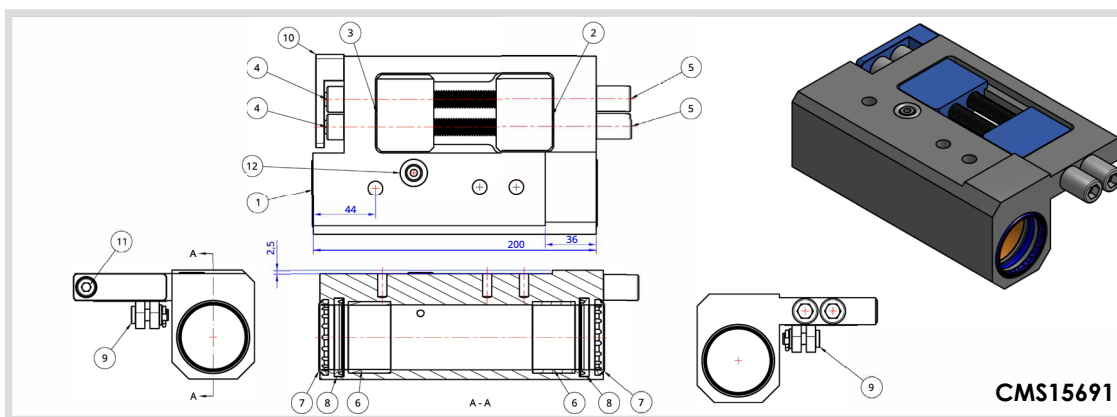

CMS15691

Installation

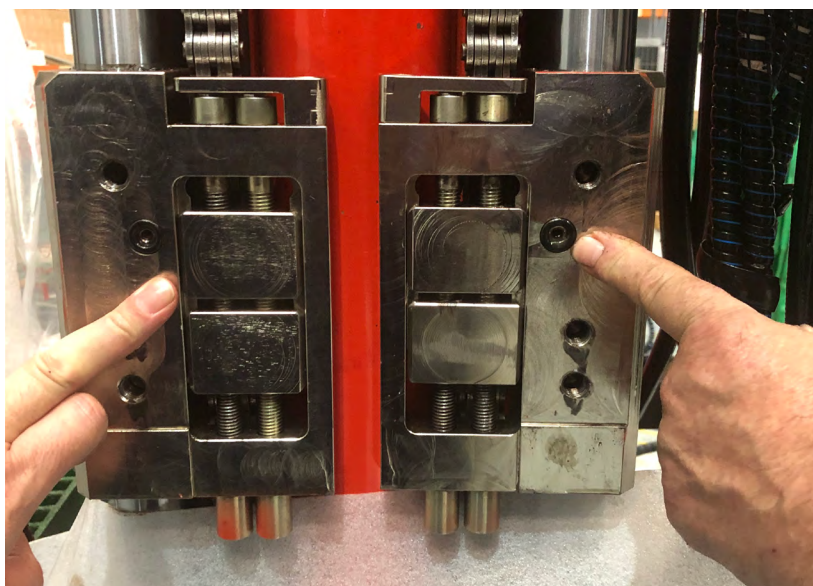

For details on how to install download our

[Drill Rig TSRU Dismount / Mount and Chain Tension Instructions.pdf](#)