

CMS15690 HFX Drill Head Chain Tensioner Right Hand Side

CMS15690 is a chain tensioner and TSRU Drill head retainer assembly for typical HFX drill rigs, used to mount the TSRU to the feed cylinder slides.

CMS15690 is typically used in conjunction with CMS15688 HFX TSRU Standoff Plate.

CMS15690 and all necessary seals, wear-strips and O rings.

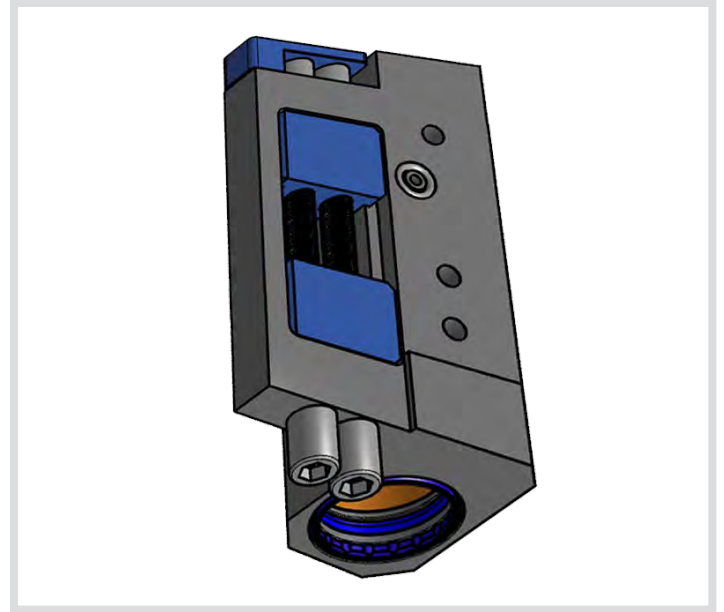

Specifications

- Weight: 5.39kg

Dimensions

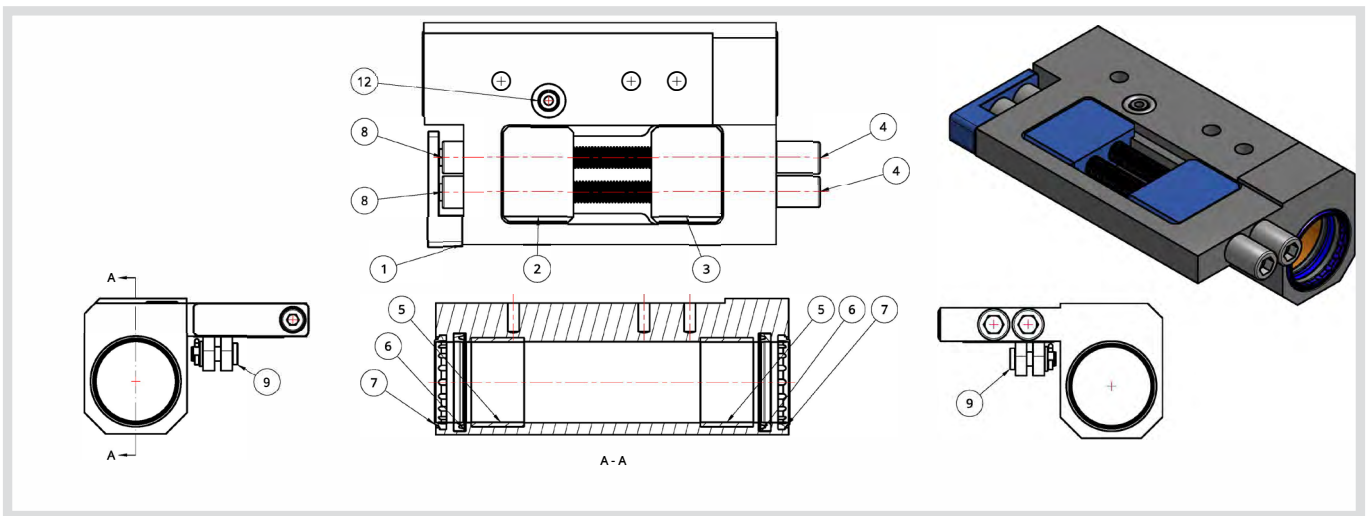

Installation

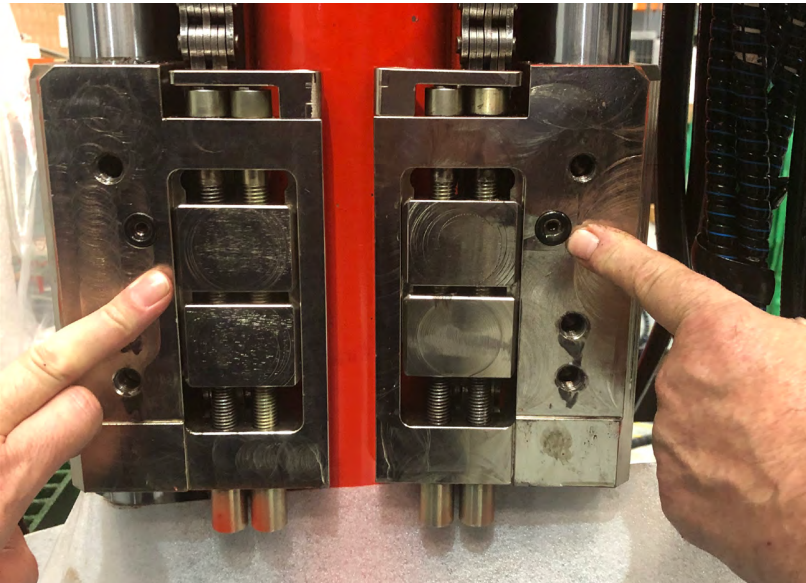

For details on how to install download our

[Drill Rig TSRU Dismount / Mount and Chain Tension Instructions.pdf](#)