

## CMS15691 HFX Drill Head Chain Tensioner Left Hand Side

CMS15691 is a chain tensioner and TSRU Drill head retainer assembly for typical HFX drill rigs, used to mount the TSRU to the feed cylinder slides.

CMS15691 is typically used in conjunction with CMS15688 HFX TSRU Standoff Plate.

CMS15691 and all necessary seals, wear-strips and O rings.

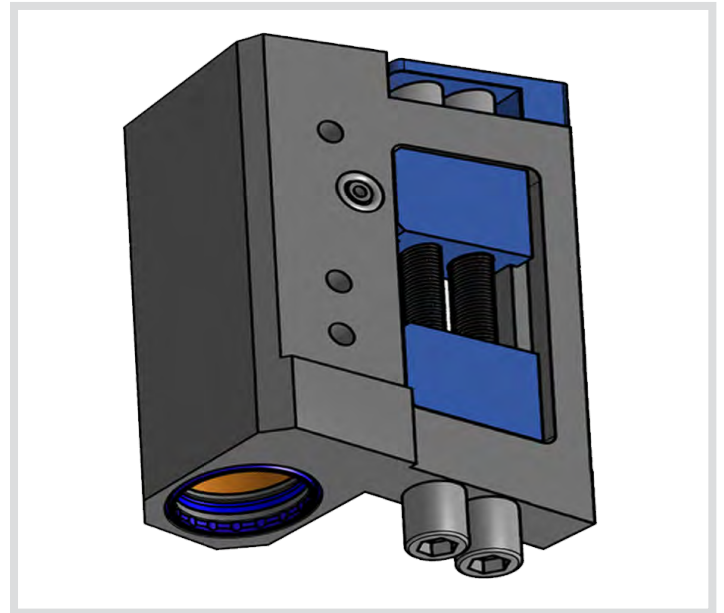

### Specifications

- Weight: 5.39kg

### Dimensions

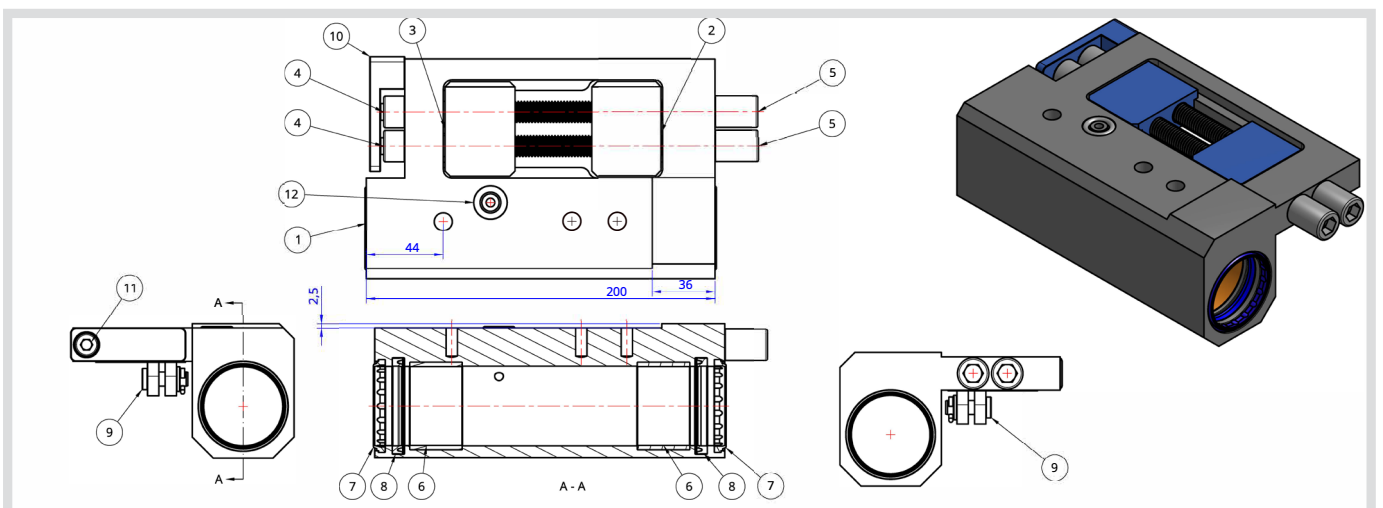

## Installation

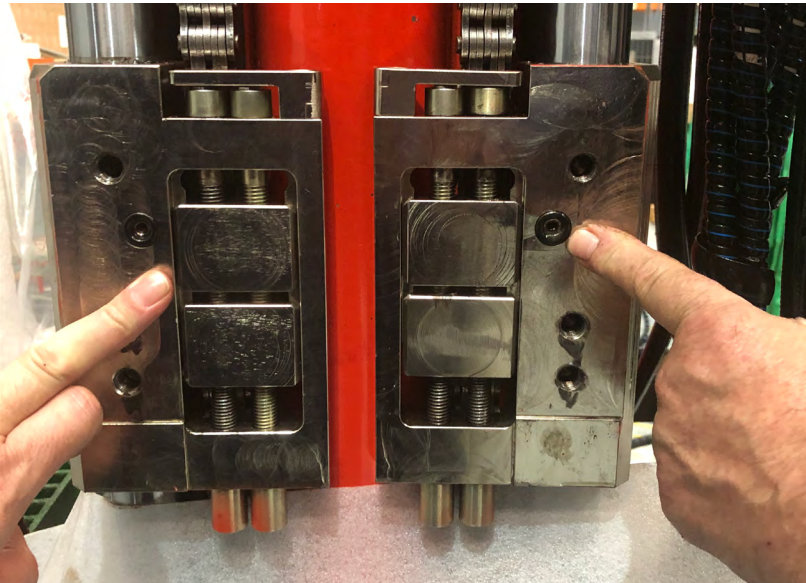

For details on how to install download our

[Drill Rig TSRU Dismount / Mount and Chain Tension Instructions.pdf](#)