

## LOSU0101 Smart Contactor 160A NEMA4

The LOSU Smart Contactor (NEMA 4) is an integrated microprocessor-based control module and 3-phase on-line motor starter package, which provides real-time control, monitoring and overload protection of a 3-phase motor. The product is built around the V201-series Eaton vacuum contactor. A current sensor sub-module is fitted to the output bus bars of the contactor and a controller circuit card is then attached to the base.

The product can be used for safe control and monitoring of 3-phase motors (and other loads) up to 1,500 volts and with continuous current delivery of 160 amperes. A host control system is required to switch and monitor the contactor. The communication between the smart contactor and the host control system is via CAN fieldbus.

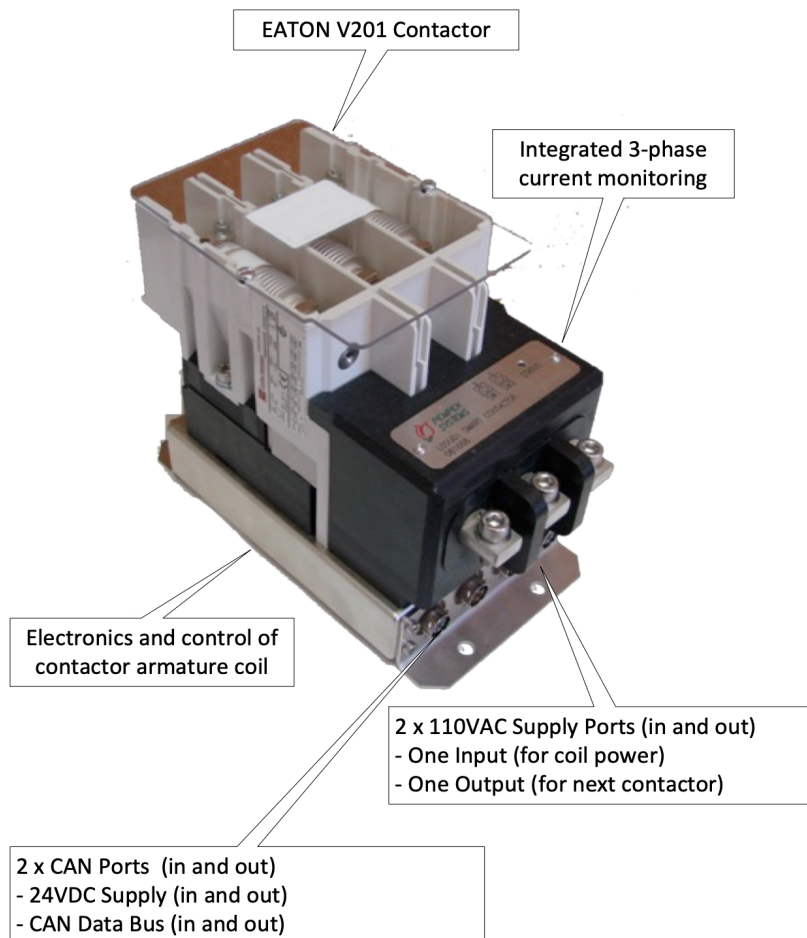
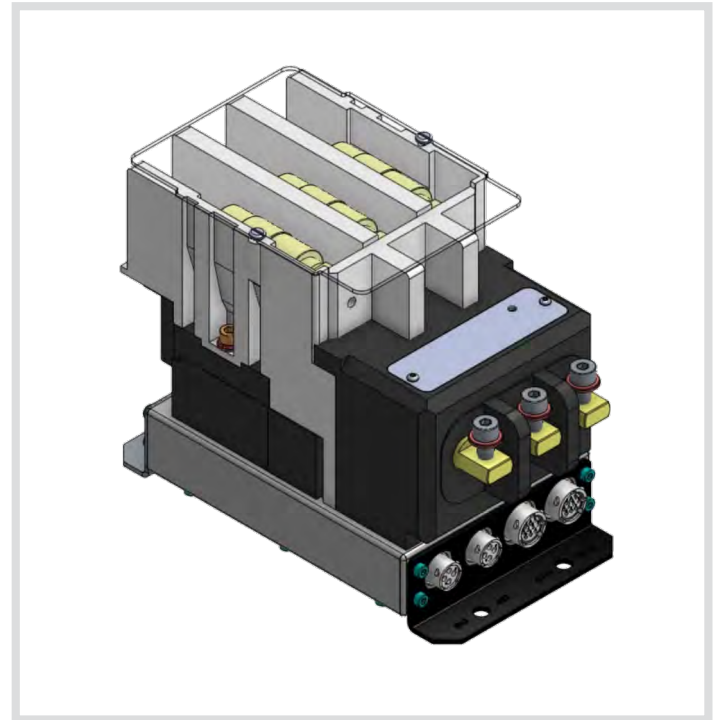

**LOSU0101 Smart Contactor 160A NEMA4**

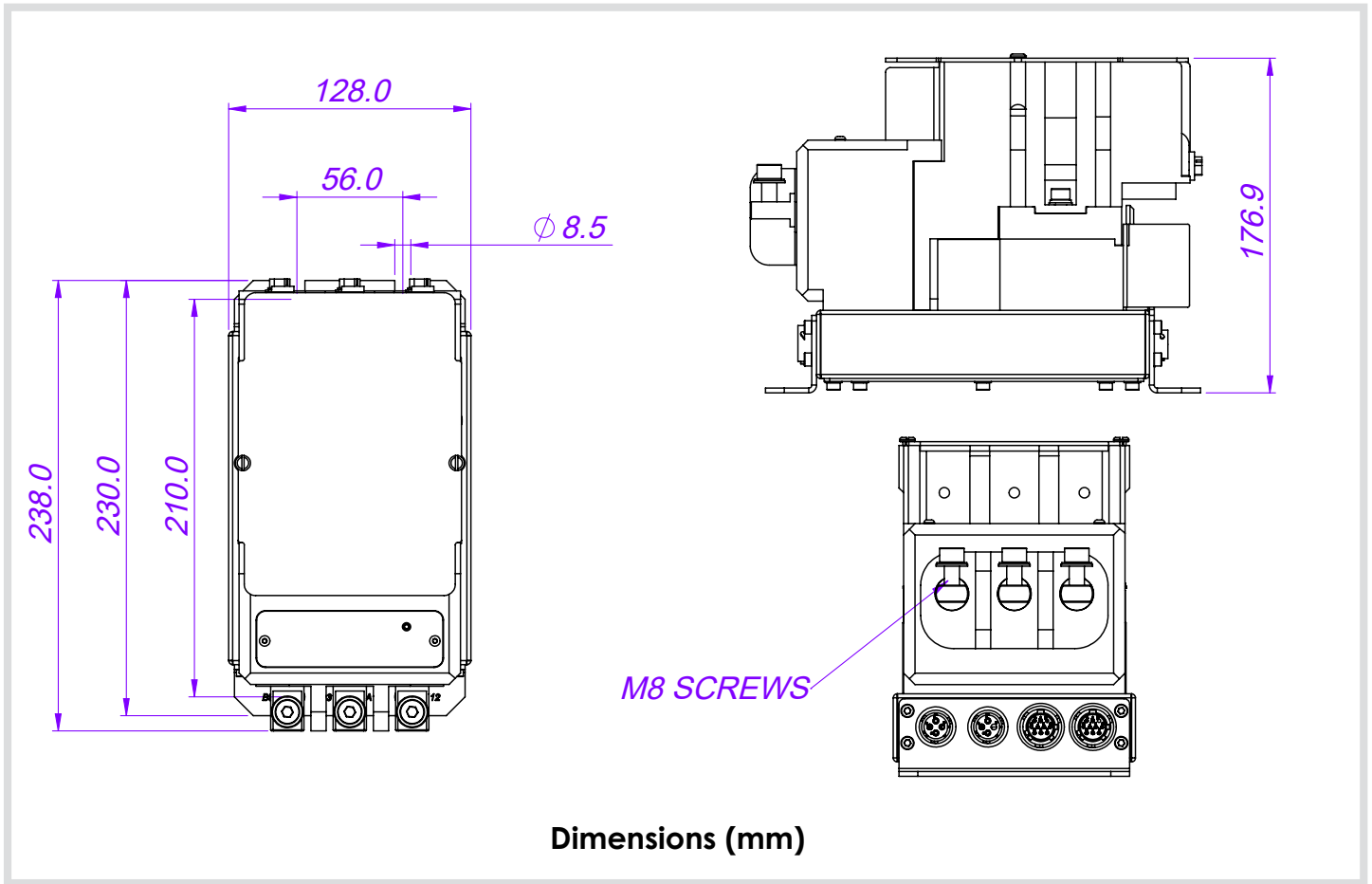

## L0SU0101 Smart Contactor 160A NEMA4

### Typical Application

Smart contactors can be used for control and monitoring of 3-phase motors (and other loads) up to 1,500 volts. The L0SU0101 model supports loads up to 160 amperes, while the L0UJ0101 device can drive loads up to 320 amperes. The L0X10101 is suitable for continuous loads up to 540 amperes. A host control system is required to switch and monitor the contactor. The communication between the smart contactor and the host control system is via CAN fieldbus protocol.

A host control system is connected to the contactor using a CAN/24VDC cable. This cable contains 24VDC supply as well as CAN fieldbus wiring.

The control system supplies 110 VAC to the contactor using a separate cable. This supplies the 110VAC source power required to switch the armature coil of the contactor.

The host control system can turn the contactor on and off by sending the correct commands over the CAN fieldbus. When the contactor is turned on (the contactor armature coil is energized with 110VAC) the armature closes and connects the incoming 3-phase power busses to the output terminals of the contactor. The load (typically a 3-phase electric motor) is then supplied with 3-phase power.

Whilst the load is energized in this way, the contactor continuously monitors the electrical current in each phase. The measured values of current are used to protect the motor against several overload and fault conditions, such as instantaneous over-current, thermal overload, phase imbalance, and phase loss. If the contactor detects any failure of this kind, it immediately turns off the 3-phase supply to the load and notifies the host control system.

In the case of a thermal overload condition (motor current was above full-load rating for too long), the contactor will not permit the host control system to re-start the motor until a cool-down period of four (4) minutes has been observed. The cool-down timer is maintained in non-volatile memory within the contactor and cannot be cleared by removing 24VDC power.

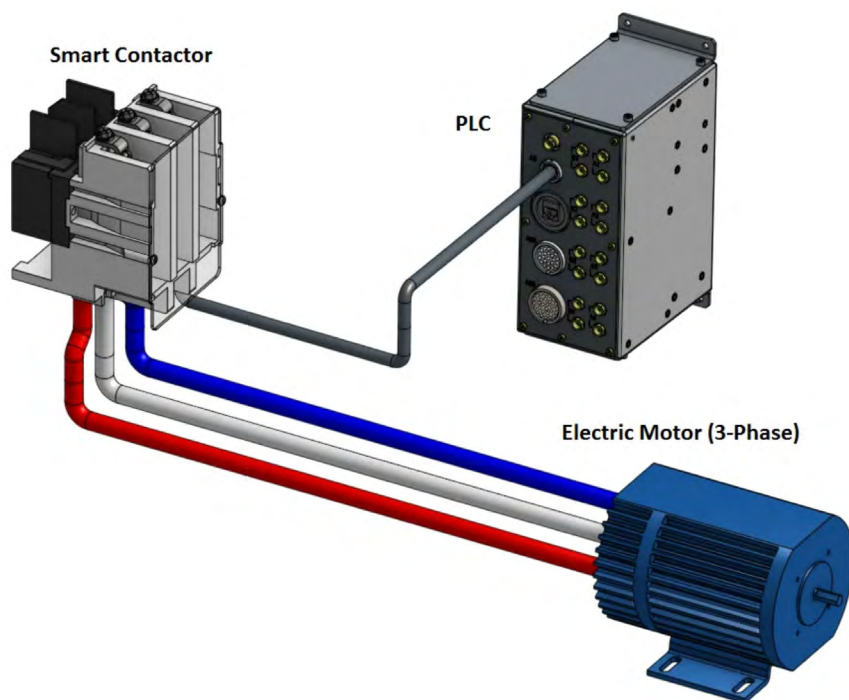

# LOSU0101 Smart Contactor 160A NEMA4

## Basic Theory of Operation

The Smart Contactor is supplied from a 24VDC power source and is connected to CAN (Controller Area Network) field bus. The contactor is also configured with a CAN address group (CAN ID Sub-address) by way of a CAN ID Plug fitted to the contactor when installed on the target machine.

Different CAN ID Plug numbers allow several contactors to be fitted to a complete machine control system and share the same physical CAN Fieldbus network.

When the contactor first receives 24VDC power, it boots and configures its CAN address (based on the connected CAN ID plug).

It then waits to receive the first COMMAND MESSAGE from the host. Once this message is received, it then begins sending status messages on the CAN bus to the host control system. The contactor sends no CAN message until the first valid host COMMAND MESSAGE is received.

The host control system must then send a configuration message to the contactor in order to configure the desired motor protection parameters. These parameter settings must suit the motor (or other types of load) that is being switched by the contactor.

## Host Management Model

The following state machine describes the actual operating states of the contactor and how they interact with control and monitoring by the host.

