

## LOWM0201 AC Drive AC Drive 1140V Choke 40A Front/Rear Mounting

AC line chokes are added to the input of the VFD and placed in series with the incoming line.

They help to mitigate harmonics and because they are between the line and the drive, they are able to act as a buffer for surges and other transients.

- 1140V 3Phase 40A
- Typically used for 1140V 60KW Motor with VFD (LOW4)

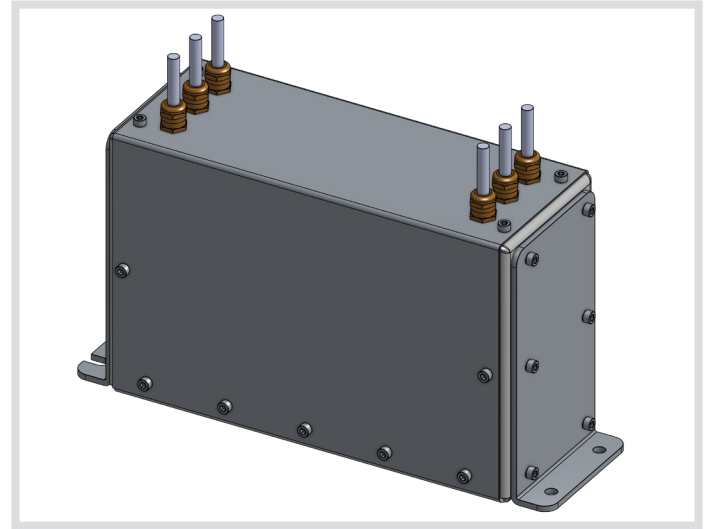

### Specifications

Inductance per phase	1.4	mH
Inductance tolerance at 25 Arms	±10	%
Operating line-line voltage, maximum	1300	Vrms
Insulation rating, phase to phase	3000	Vrms
Insulation rating, phase to core/chassis	3000	Vrms
Line current, 1 hour thermal rating	40	Arms
Line current, core saturation	80	Arms

