

L0PE0201 Obelix PWM Rexroth Proportional Solenoid Driver Module Type B

The L0PE2101 Obelix Mining PLC Solenoid Driver Module provides PWM - controlled proportional outputs in a compact, robust form factor that is well suited to mobile mining applications.

The industry-standard CAN (Controller Area Network) connection provides a host PLC with the ability to control and monitor all outputs.

Uniquely Keyed Type C and D connectors to prevent incorrect machine installation

22 x PWM current-controlled 24VDC Proportional outputs (up to 1A continuous rating)

Module Type: Multi-channel Solenoid Driver

Supply Input 1: 24VDC (+/- 10%) / 3 Watts (Max)

Supply Input 2: 24VDC (+/- 10%) / 550 Watts (Max)
(based on output loads)

Data Communications: Obelix CAN (A2)

Operating Temperature: -20°C to 70°C

Inputs: None

Outputs: 22 x PWM Current-regulated Outputs (1A Maximum)

Connector 1: Obelix A2 (24VDC Input + CAN Bus)

Connector 2: Obelix C30
(PWM Outputs and 24VDC PWM Supply Input)

Connector 3: Obelix D30
(PWM Outputs and 24VDC PWM Supply Input)

Heavy Duty Enclosure:
Electros Nickel Plated
Rugged Construction

Fasteners

M5 x 10mm x 4

M4 x 10mm x 8

M3 x 10mm x 8

Mass

3.5kg (7.7lb)



Typical Applications

- Continuous Bolter/Miners
- Continuous Haulage
- Long Wall Shearers
- Mobile Bolters
- Mobile Roof Supports
- Remote Control Scoops
- Remote Control Loaders
- Any industrial switching application

L0PE0201 Obelix PWM Rexroth Proportional Solenoid Driver Module Type B

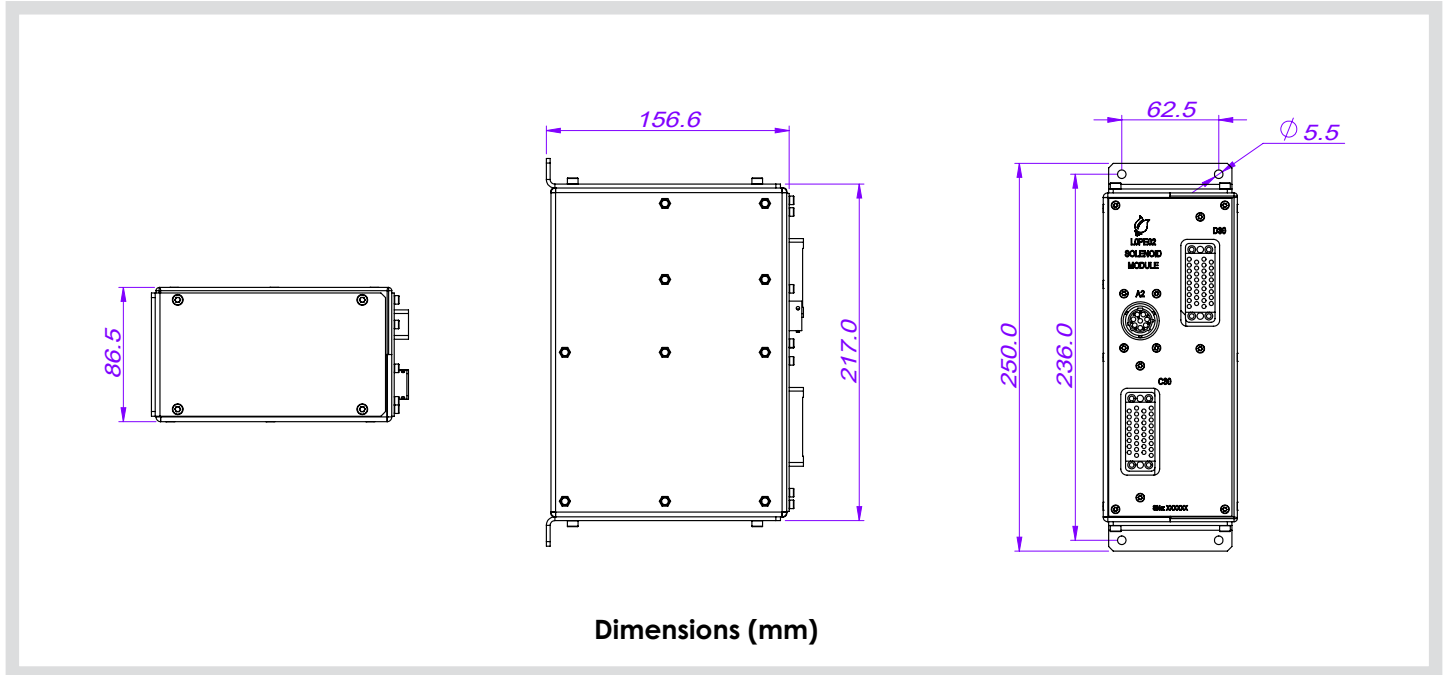

Dimensions (mm)

CONNECTOR A2

PIN	Connector A2 Burndy Female 8 Way	Signal
A2-A	Supply Input	24VDC Supply Input
A2-B	Supply Input	0VDC Supply Input
A2-C	CAN A (Positive)	Communications
A2-D	CAN A (Positive)	Communications
A2-E	CAN A (Negative)	Communications
A2-F	CAN A (Negative)	Communications
A2-G	Termination Link 1 - 1	Termination Link Input
A2-H	Termination Link 1 - 2	Termination Link Input



L0PE0201 Obelix PWM Rexroth Proportional Solenoid Driver Module Type B

CONNECTOR C30

Number	Unit / PCB V-35 Female Board Mount PIN	Name
1	A	Solenoid 33 Positive
2	B	Solenoid 32 Positive
3	C	Solenoid 33 Negative
4	D	Solenoid 32 Negative
5	E	CAN Address 2
6	F	Solenoid 31 Positive
7	H	CAN Address 1
8	J	Solenoid 31 Negative
9	K	CAN Address 0
10	L	Solenoid 30 Positive
11	M	RS-232 Comms
12	N	Solenoid 29 Negative
13	P	RS-232 Comms
14	R	Solenoid 28 Negative
15	S	RS-232 Comms
16	T	Solenoid 28 Positive
17	U	Solenoid 23 Positive
18	V	Solenoid 27 Negative
19	W	Solenoid 23 Negative
20	X	Solenoid 27 Positive
21	Y	Solenoid 24 Positive
22	Z	Solenoid 27 Negative
23	AA	Solenoid 24 Negative
24	BB	Solenoid 27 Positive
25	CC	Solenoid 25 Positive
26	DD	Solenoid 26 Negative
27	EE	Solenoid 25 Negative
28	FF	Solenoid 26 Positive
29	HH	24V SOLENOID SUPPLY
30	JJ	0V SOLENOID SUPPLY
31	KK	24 SOLENOID SUPPLY
32	LL	0V SOLENOID SUPPLY
33	MM	24V SOLENOID SUPPLY
34	NN	0V SOLENOID SUPPLY



Image depict coding pins required

L0PE0201 Obelix PWM Rexroth Proportional Solenoid Driver Module Type B

CONNECTOR D30

Number	Unit / PCB VMCT-34F Female Board Mount PIN	Name
1	A	Solenoid 44 Positive
2	B	Solenoid 43 Positive
3	C	Solenoid 44 Negative
4	D	Solenoid 43 Negative
5	E	CAN Address Modifier 2
6	F	Solenoid 42 Positive
7	H	CAN Address Modifier 1
8	J	Solenoid 42 Negative
9	K	CAN Address Modifier 1
10	L	Solenoid 41 Positive
11	M	RS-232 Transmit
12	N	Solenoid 41 Negative
13	P	RS-232 Receive
14	R	Solenoid 40 Negative
15	S	RS-232 0VDC Reference
16	T	Solenoid 40 Positive
17	U	Solenoid 34 Positive
18	V	Solenoid 39 Negative
19	W	Solenoid 34 Negative
20	X	Solenoid 39 Positive
21	Y	Solenoid 35 Positive
22	Z	Solenoid 38 Negative
23	AA	Solenoid 35 Negative
24	BB	Solenoid 38 Positive
25	CC	Solenoid 36 Positive
26	DD	Solenoid 37 Negative
27	EE	Solenoid 36 Negative
28	FF	Solenoid 37 Positive
29	HH	Solenoid Supply 24VDC
30	JJ	Solenoid Supply 0VDC
31	KK	Solenoid Supply 24VDC
32	LL	Solenoid Supply 0VDC
33	MM	Solenoid Supply 24VDC
34	NN	Solenoid Supply 0VDC



Image depict coding pins required

L0PE0201 Obelix PWM Rexroth Proportional Solenoid Driver Module Type B

Connector Assembly

Part Number	Description
HOPE0301	Connector Assembly C30
HOPE0401	Connector Assembly D30

Connector Assembly Specifications

- **Product Type:** Pre-manufactured cable assembly
- **Construction:** Connector with flying leads (pigtail)
- **HOPE0301 Connector 1 :** Obelix C30 Male Plug (34-pin)
- **HOPE0401 Connector 1 :** Obelix D30 Male Plug (34-pin)
- **Connector 2:** Unterminated, flying leads
- **Conductors:** 26
- **Cable Length:** 2.2 metres
- **Pin Type: Female** (Gold-plated)
- **Conductor Type:** PVDF Tinned Stranded Wire
- **Insulation Rating:** 600 volts
- **Temperature Rating:** -65°C to 105°C
- **Recommended Tools:** PVDF / Teflon Insulation Stripping Tool