

## LORR0401 Obelix Module Rexroth Solenoid I/O Module Type D

The LORR0401 Obelix Mining PLC Solenoid Driver I/O Module combines PWM - controlled proportional outputs along with digital and analog inputs in a compact housing ideal for mobile mining equipment applications where installation space is limited.

The industry-standard CAN (Controller Area Network) connection provides a host PLC with the ability to control and monitor all outputs and inputs.

Uniquely Keyed Type A and Type B connectors to prevent incorrect machine installation.

- **Module Type:** Multi-channel Solenoid Driver
- **Supply Input 1:** 24VDC (+/- 10%) / 3 Watts (Max)
- **Supply Input 2:** 24VDC (+/- 10%) / 550 Watts (Max) (based on output loads)
- **Data Communications:** Obelix CAN (A2)
- **Operating Temperature:** -20°C to 70°C
- **Inputs:** None
- **Outputs:** 22 x PWM Current-regulated Outputs (1 A Maximum)
- **Connector 1:** Obelix A2 (24VDC Input + CAN Bus)
- **Connector 2:** Obelix G30 (PWM Outputs and 24VDC PWM Supply Input)
- **Connector 3:** Obelix H30 (PWM Outputs and 24VDC PWM Supply Input)
- **Connector 4:** Obelix D47 (Inputs)



### Typical Application

- Continuous Bolter/Miners
- Continuous Haulage
- Long Wall Shearers
- Mobile Bolters
- Mobile Roof Supports
- Remote Control Scoops
- Remote Control Loaders
- Any industrial switching application

LORR0401 Obelix Module Rexroth Solenoid I/O Module Type D

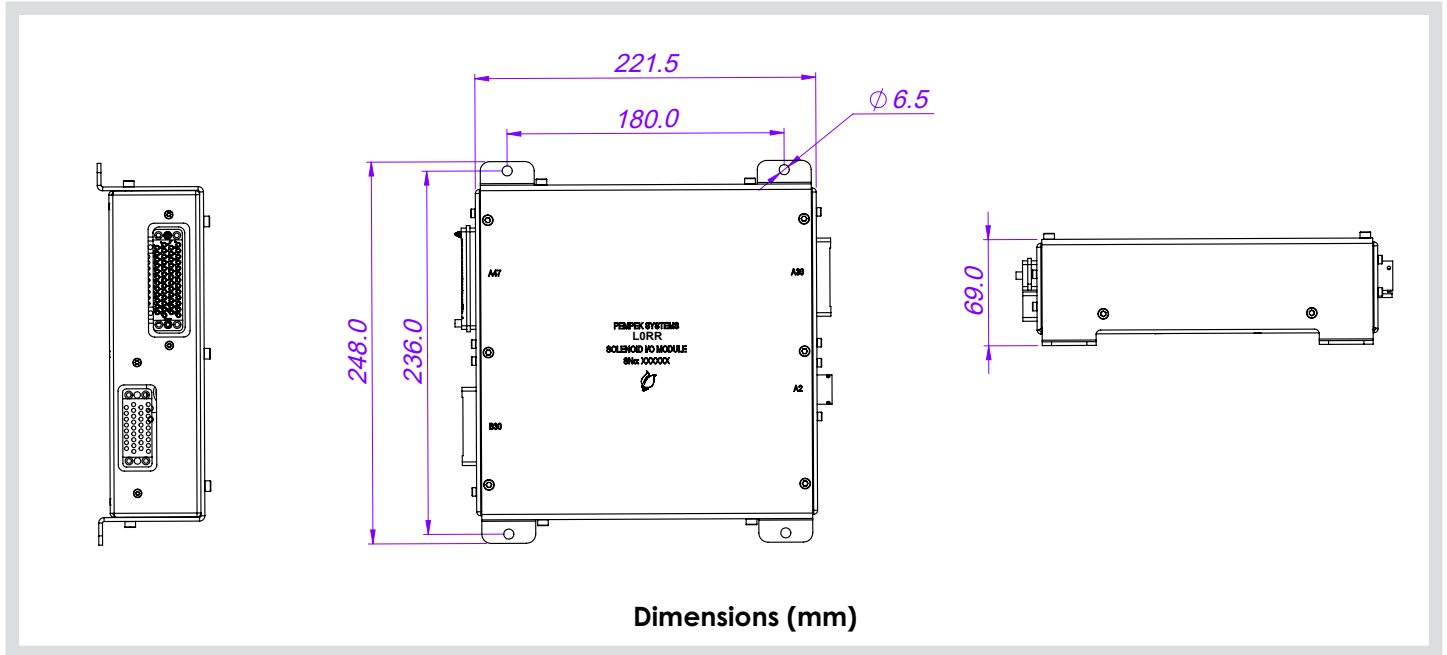

**CONNECTOR A2**

PIN	Connector A2 Burndy Female 8 Way	Signal
A2-A	Supply Input	24VDC Supply Input
A2-B	Supply Input	0VDC Supply Input
A2-C	CAN A (Positive)	Communications
A2-D	CAN A (Positive)	Communications
A2-E	CAN A (Negative)	Communications
A2-F	CAN A (Negative)	Communications
A2-G	Termination Link 1 - 1	Communications
A2-H	Termination Link 1 - 2	Communications



## L0RR0401 Obelix Module Rexroth Solenoid I/O Module Type D

### CONNECTOR G30

PIN	Connector G30 V35 Female No.	Signal
A30-A	Solenoid 64 Positive	24VDC Switched
A30-B	Solenoid 65 Positive	24VDC Switched
A30-C	Solenoid 64 Negative	24VDC Return
A30-D	Solenoid 65 Negative	24VDC Return
A30-E	CAN Address Modifier 2	24VDC Digital Input
A30-F	Solenoid 63 Positive	24VDC Switched
A30-H	CAN Address Modifier 1	24VDC Digital Input
A30-J	Solenoid 63 Negative	24VDC Return
A30-K	CAN Address Modifier 0	24VDC Digital Input
A30-L	Solenoid 62 Positive	24VDC Switched
A30-M	RS-232 Transmit	Communications
A30-N	Solenoid 62 Negative	24VDC Return
A30-P	RS-232 Receive	Communications
A30-R	Solenoid 61 Negative	24VDC Return
A30-S	RS-232 0VDC Reference	Communications
A30-T	Solenoid 61 Positive	24VDC Switched
A30-U	Solenoid 55 Positive	24VDC Switched
A30-V	Solenoid 60 Negative	24VDC Return
A30-W	Solenoid 55 Negative	24VDC Return
A30-X	Solenoid 60 Positive	24VDC Switched
A30-Y	Solenoid 56 Positive	24VDC Switched
A30-Z	Solenoid 59 Negative	24VDC Return
A30-AA	Solenoid 56 Negative	24VDC Return
A30-BB	Solenoid 59 Positive	24VDC Switched
A30-CC	Solenoid 57 Positive	24VDC Switched
A30-DD	Solenoid 58 Negative	24VDC Return
A30-EE	Solenoid 57 Negative	24VDC Return
A30-FF	Solenoid 58 Positive	24VDC Switched
A30-HH	Solenoid Supply 24VDC	24VDC Supply Input
A30-JJ	Solenoid Supply 24VDC	0VDC Supply Input
A30-KK	Solenoid Supply 24VDC	24VDC Supply Input
A30-LL	Solenoid Supply 24VDC	0VDC Supply Input
A30-MM	Solenoid Supply 24VDC	24VDC Supply Input
A30-NN	Solenoid Supply 24VDC	0VDC Supply Input



Image depict coding pins required



## LORR0401 Obelix Module Rexroth Solenoid I/O Module Type D

### CONNECTOR H30

PIN	Connector H30 V35 Female No.	Signal
B30-A	Solenoid 76 Positive	24VDC Switched
B30-B	Solenoid 75 Positive	24VDC Switched
B30-C	Solenoid 76 Negative	24VDC Return
B30-D	Solenoid 75 Negative	24VDC Return
B30-E	CAN Address Modifier 2	24VDC Digital Input
B30-F	Solenoid 74 Positive	24VDC Switched
B30-H	CAN Address Modifier 1	24VDC Digital Input
B30-J	Solenoid 74 Negative	24VDC Return
B30-K	CAN Address Modifier 0	24VDC Digital Input
B30-L	Solenoid 73 Positive	24VDC Switched
B30-M	RS-232 Transmit	Communications
B30-N	Solenoid 73 Negative	24VDC Return
B30-P	RS-232 Receive	Communications
B30-R	Solenoid 72 Negative	24VDC Return
B30-S	RS-232 0VDC Reference	Communications
B30-T	Solenoid 72 Positive	24VDC Switched
B30-U	Solenoid 66 Positive	24VDC Switched
B30-V	Solenoid 71 Negative	24VDC Return
B30-W	Solenoid 66 Negative	24VDC Return
B30-X	Solenoid 71 Positive	24VDC Switched
B30-Y	Solenoid 67 Positive	24VDC Switched
B30-Z	Solenoid 70 Negative	24VDC Return
B30-AA	Solenoid 67 Negative	24VDC Return
B30-BB	Solenoid 70 Positive	24VDC Switched
B30-CC	Solenoid 68 Positive	24VDC Switched
B30-DD	Solenoid 69 Negative	24VDC Return
B30-EE	Solenoid 68 Negative	24VDC Return
B30-FF	Solenoid 69 Positive	24VDC Switched
B30-HH	Solenoid Supply 24VDC	24VDC Supply Input
B30-JJ	Solenoid Supply 24VDC	0VDC Supply Input
B30-KK	Solenoid Supply 24VDC	24VDC Supply Input
B30-LL	Solenoid Supply 24VDC	0VDC Supply Input
B30-MM	Solenoid Supply 24VDC	24VDC Supply Input
B30-NN	Solenoid Supply 24VDC	0VDC Supply Input



Image depict coding pins required

## LORR0401 Obelix Module Rexroth Solenoid I/O Module Type D

### CONNECTOR D4

PIN	Connector D47 V35 Female	Signal
A47-A	CAN ID0	0VDC Input
A47-B	Module Supply	24VDC Supply Input
A47-C	Module Supply Return	0VDC Supply Return
A47-D	Quadrature Encoder A - Counter1	24VDC Input
A47-E	CAN ID1	0VDC Input
A47-F	Quadrature Encoder A - Counter2	24VDC Input
A47-H	0VDC CAN ID Reference	0VDC CAN ID
A47-J	Quadrature Encoder B - Counter3	24VDC Input
A47-K	CAN ID2	0VDC Input
A47-L	Quadrature Encoder B - Counter4	24VDC Input
A47-M	INP2 - Digital Input	24VDC Input
A47-N	INP1 - Digital Input	24VDC Input
A47-P	INP4 - Digital Input	24VDC Input
A47-R	INP3 - Digital Input	24VDC Input
A47-S	INP6 - Digital Input	24VDC Input
A47-T	INP5 - Digital Input	24VDC Input
A47-U	INP8 - Digital Input	24VDC Input
A47-V	INP7 - Digital Input	24VDC Input
A47-W	INP10 - Digital Input	24VDC Input
A47-X	INP9 - Digital Input	24VDC Input
A47-Y	INP12 - Digital Input & Pulse Counter 2	24VDC Input
A47-Z	INP11 - Digital Input & Pulse Counter 1	24VDC Input
A47-a	AN2 - Analog Input	4-20mA Input
A47-b	AN1 - Analog Input	4-20mA Input
A47-c	AN4 - Analog Input	4-20mA Input
A47-d	AN3 - Analog Input	4-20mA Input
A47-e	AN6 - Analog Input	4-20mA Input
A47-f	AN5 - Analog Input	4-20mA Input
A47-h	AN8 - Analog Input	4-20mA Input
A47-j	AN7 - Analog Input	4-20mA Input
A47-k	AN10 - Analog Input	4-20mA Input
A47-m	AN9 - Analog Input	4-20mA Input
A47-n	AN12 - Analog Input	4-20mA Input
A47-p	AN11 - Analog Input	4-20mA Input
A47-r	AN14 - Analog Input	4-20mA Input
A47-s	AN13 - Analog Input	4-20mA Input
A47-t	AN16 - Analog Input	4-20mA Input
A47-u	AN15 - Analog Input	4-20mA Input
A47-v	AN18 - Analog Input	4-20mA Input
A47-w	AN17 - Analog Input	4-20mA Input
A47-x	Supply Input	110VAC Neutral
A47-y	Analog Supply Output	24VDC Supply Output
A47-z	DG12 - Digital Input	110VAC Input
A47-AA	DG11 - Digital Input	110VAC Input
A47-BB	DG14 - Digital Input	110VAC Input
A47-CC	DG13 - Digital Input	110VAC Input
A47-DD	DG16 - Digital Input	110VAC Input
A47-EE	DG15 - Digital Input	110VAC Input
A47-FF	DG18 - Digital Input	110VAC Input
A8-HH	DG17 - Digital Input	220VAC Digital Input

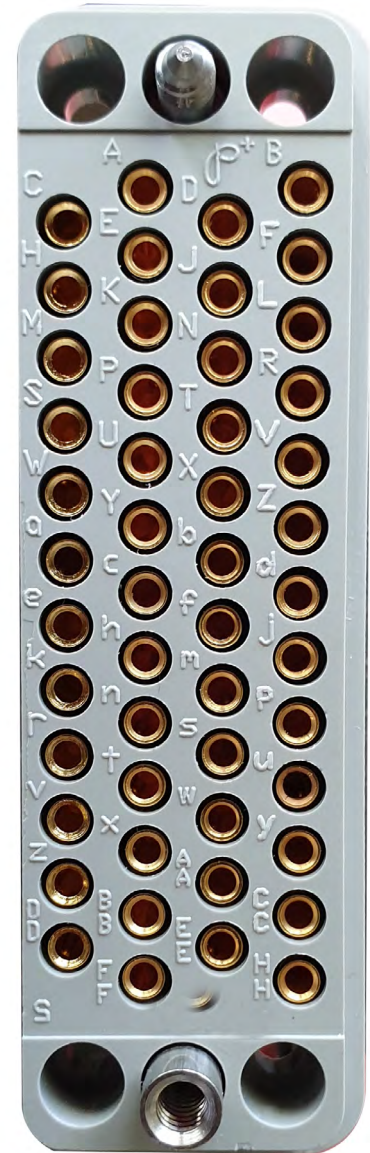

Image depict coding pins required