

## LORU1501 Obelix Module - Receiver Control CAN3 External LINK Generic

The LORU1501 is an Obelix Mining PLC Processor module is used for legacy mobile mining machinery control and automation applications that are programmed and maintained by Pempek automation software developers.

The LORU1501 model does not provide an AS4871-compliant clock/memory retention battery and is therefore not suitable for new machine automation designs.

In addition to sixteen (16) local digital inputs (24VDC); the module provides a number of field bus options - including CAN (4), RS-422 (4) and RS-232 (1).

The module also supports Pempek CAN Fibre ports (8 channels) for convenient, reliable control and monitoring of Obelix Mining PLC I/O modules. Two (2) CAN channels are shared with Fibre Ports (distributed with 4 ports each).

A built-in radio data receiver directly supports radio remote control applications.



- Module Type:** Processor Module (with built-in radio control receiver)
- Supply Input:** 24VDC (+/- 10%) / 5 Watts (Max)
- Data Communications:** Copper CAN (4), Fibre CAN (1 shared with Copper CAN), RS-422 (3), RS-232 (2), Radio Control Receiver
- Operating Temperature:** -20 to 70 C
- Inputs:** 16 x Digital Inputs (24VDC)
- Outputs:** 1 x C-Form Relay (110VAC / 8 A)
- Connector 1:** Obelix A2 (24VDC Input + CAN Bus A)
- Connector 2:** Ethernet RJ-45 (Programming)
- Connector 3:** Obelix Data A68 (CAN B,C,D, RS422, RS232)
- Connector 4:** Obelix A69 (Digital Inputs, Relay Output)
- Connector 5:** BNC Coax (Radio Control Antenna Input)

### CONNECTOR A2

PIN	Connector A2 Burdy Female 8 Way	Signal
A2-A	Supply Input	24VDC Supply Input
A2-B	Supply Input	0VDC Supply Input
A2-C	CAN A (Positive)	Communications
A2-D	CAN A (Positive)	Communications
A2-E	CAN A (Negative)	Communications
A2-F	CAN A (Negative)	Communications
A2-G	Termination Link 1 - 1	Termination Link Input
A2-H	Termination Link 1 - 2	Termination Link Input



## LORU1501 Obelix Module - Receiver Control CAN3 External LINK Generic

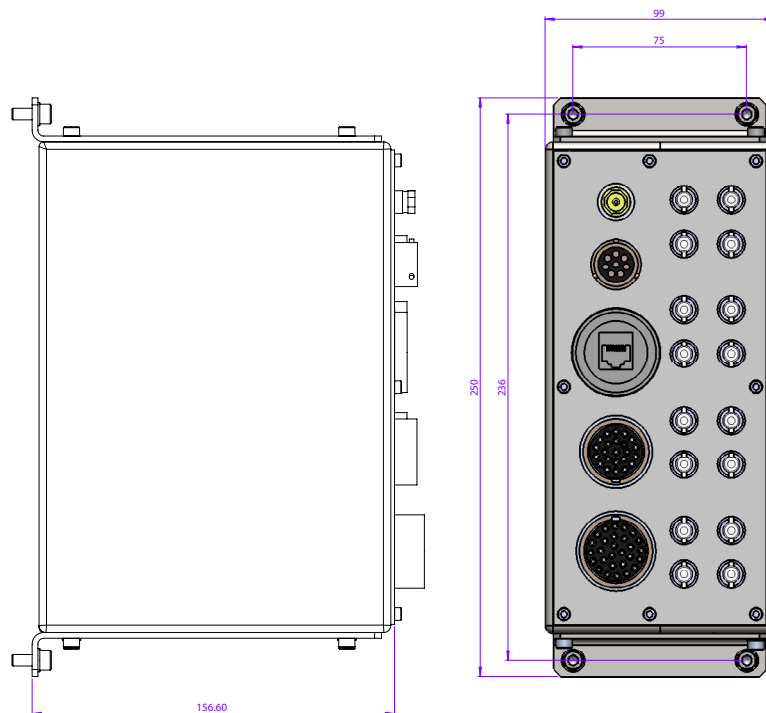

Dimensions (mm)

### CONNECTOR A68

No.	Connector A68 23 (32) Burndy Female PIN	Name
1	A	CANH1
2	B	CANL1
3	C	CANH2
4	D	CANL2
5	E	CANH3
6	F	CANL3
7	G	0VDC
8	H	RXA-
9	J	RXA+
10	K	TXA-
11	L	TXA+
12	M	RXB- /CTS B
13	N	RXB+ /RXB
14	P	TXB- / TXB
15	R	TXB+ /RTSB
16	S	0VDC
17	T	RXC-
18	U	RXC+
19	V	TXC-
20	W	TXC+
21	X	RXD
22	Y	TXD
23	Z	0VDC



## LORU1501 Obelix Module - Receiver Control CAN3 External LINK Generic

### CONNECTOR A69

No.	Connector A69 28 (41) Burndy Female PIN	Name
1	A	DGI-1
2	B	DGI-2
3	C	DGI-3
4	D	DGI-4
5	E	DGI-5
6	F	DGI-6
7	G	DGI-7
8	H	DGI-8
9	J	DGI-9
10	K	DGI-10
11	L	DGI-11
12	M	DGI-12
13	N	DGI-13
14	P	DGI-14
15	R	DGI-15
16	S	DGI-16
17	T	0VDC
18	U	CAN 1-L1
19	V	CAN 1-L2
20	W	COLDFIRE UART RX-
21	X	COLDFIRE UART RX+
22	Y	COLDFIRE UART TX-
23	Z	COLDFIRE UART TX+
24	a	CAN 2-L1
25	b	CAN 2-L2
26	c	RELAY IN
27	d	RELAY NC
28	e	RELAY NO



### Fibre Optic Patch ST-ST Multi-mode

Part Number	Description
H0LW0401	Fibre Optic Patch ST-ST Multi-mode

### Connector Assembly

Part Number	Description
H0RU0201	Connector Assembly A68
H0RU0301	Connector Assembly A69

### Specifications

- **Product Type:** Pre-manufactured cable assembly
- **Construction:** Fibre-optic with ST terminations
- **Connector 1 :** Fibre ST Connector (2 connectors)
- **Connector 2:** Fibre ST Connector (2 connectors)
- **Conductors:** 2
- **Cable Length:** 0.8 metres
- **Pin Type:** ST Fibre Plugs
- **Conductor Type:** Multi-mode Fibre-optic
- **Insulation Rating:** N/A
- **Temperature Rating:** -40°C to 85 °C