

L0V41101 ObelixPLUS Processor Module

The L0V41101 is an ObelixPlus Mining PLC Processor module ideal for legacy mobile mining machinery control and automation applications that are programmed and maintained by Pempek automation software developers.

A fully AS4871-compliant internal battery preserves parameter memory and real-time clock functionality when mains machine power is removed.

In addition to sixteen (16) local digital inputs (24VDC); the module provides a number of field bus options - including CAN (4), RS-422 (3) and RS-232 (1).



- **Module Type:** Processor Module
- **Supply Input:** 24VDC (+/- 10%) / 5 Watts (Max)
- **Data Communications:** CAN (4), RS-422 (3), RS-232 (2)
- **Operating Temperature:** -20°C to 70°C
- **Inputs:** 16 x Digital Inputs (24VDC)
- **Outputs:** 1 x C-Form Relay (110VAC / 8 A)
- **Connector 1:** Obelix A2 (24VDC Input + CAN Bus A)
- **Connector 2:** Ethernet RJ-45 (Programming)
- **Connector 3:** Obelix Data A68 (CAN B,C,D, RS422, RS232)
- **Connector 4:** Obelix A69 (Digital Inputs, Relay Output)

CONNECTOR A2

PIN	Connector A2 Burndy Female 8 Way	Signal
A2-A	Supply Input	24VDC Supply Input
A2-B	Supply Input	0VDC Supply Input
A2-C	CAN A (Positive)	Communications
A2-D	CAN A (Positive)	Communications
A2-E	CAN A (Negative)	Communications
A2-F	CAN A (Negative)	Communications
A2-G	Termination Link 1 - 1	Termination Link Input
A2-H	Termination Link 1 - 2	Termination Link Input



L0V41101 ObelixPLUS Processor Module

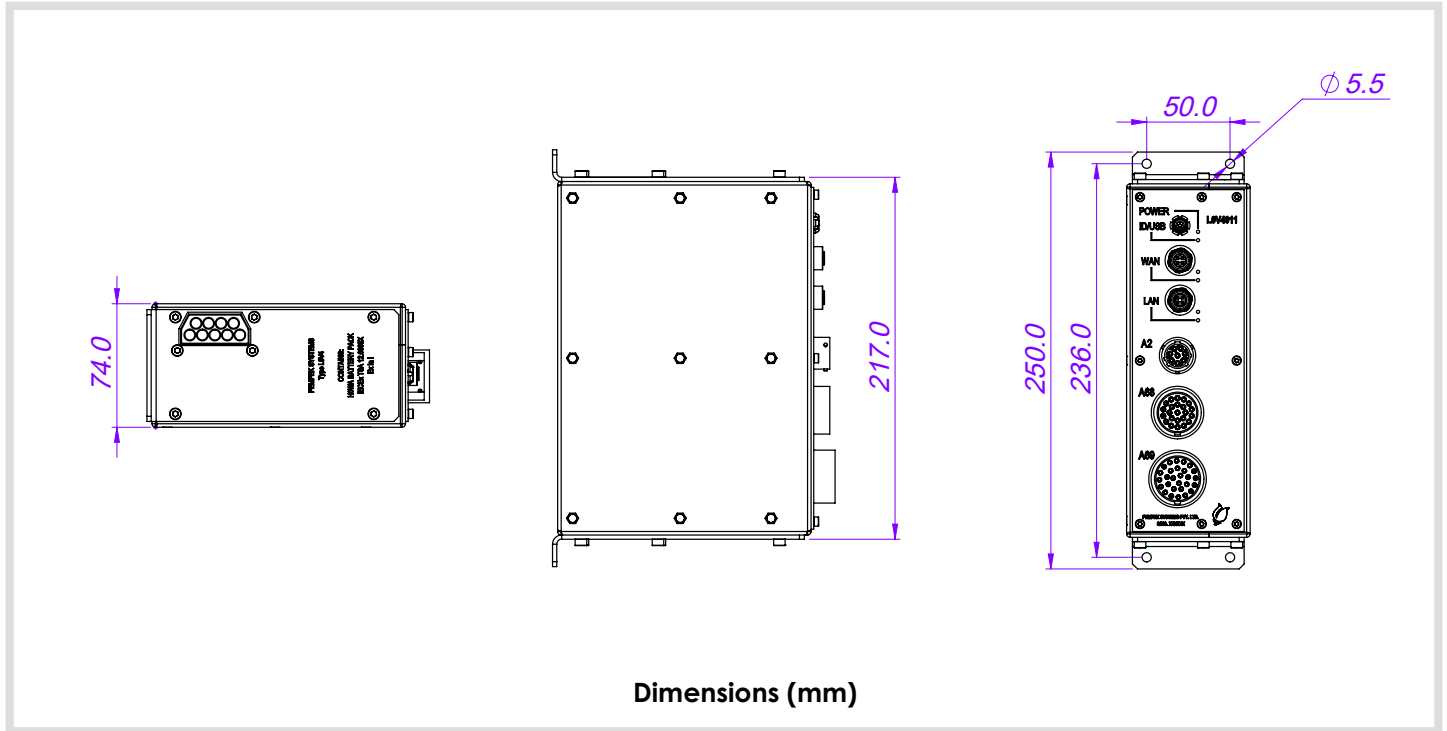

Dimensions (mm)

CONNECTOR A68

No.	Connector A68 23 (32) Burndy Female PIN	Name
1	A	CANH1
2	B	CANL1
3	C	CANH2
4	D	CANL2
5	E	CANH3
6	F	CANL3
7	G	0VDC
8	H	RXA-
9	J	RXA+
10	K	TXA-
11	L	TXA+
12	M	RXB- /CTS B
13	N	RXB+ /RXB
14	P	TXB- / TXB
15	R	TXB+ /RTSB
16	S	0VDC
17	T	RXC-
18	U	RXC+
19	V	TXC-
20	W	TXC+
21	X	RXD
22	Y	TXD
23	Z	0VDC



L0V41101 ObelixPLUS Processor Module

CONNECTOR A69

No.	Connector A69 28 (41) Burndy Female PIN	Name
1	A	DGI-1
2	B	DGI-2
3	C	DGI-3
4	D	DGI-4
5	E	DGI-5
6	F	DGI-6
7	G	DGI-7
8	H	DGI-8
9	J	DGI-9
10	K	DGI-10
11	L	DGI-11
12	M	DGI-12
13	N	DGI-13
14	P	DGI-14
15	R	DGI-15
16	S	DGI-16
17	T	0VDC
18	U	CAN 1-L1
19	V	CAN 1-L2
20	W	COLDFIRE UART RX-
21	X	COLDFIRE UART RX+
22	Y	COLDFIRE UART TX-
23	Z	COLDFIRE UART TX+
24	a	CAN 2-L1
25	b	CAN 2-L2
26	c	RELAY IN
27	d	RELAY NC
28	e	RELAY NO

