

LOZU0101 Obelix Processor Module Telemetry and Automation

The LOZU0101 Obelix Mining PLC Telemetry and Automation Processor (TAP) combines a standard Obelix automation platform with a dedicated machine telemetry processor.

This dual-processing architecture, provides segregated, high-performance management of both real-time machine automation and machine data collection.

A fully AS4871-compliant internal battery preserves parameter memory and real-time clock functionality when mains machine power is removed.

In addition to sixteen (16) local digital inputs (24VDC); the module provides a number of field bus options - including CAN (4), Ethernet (2) and RS-422 (3).

The module also supports Pempek CAN Fibre ports (8 channels) for convenient, reliable control and monitoring of Obelix Mining PLC IS I/O modules.

One (1) CAN channels is shared with the Fibre ports.



- **Module Type:** Telemetry and Processor (TAP) Module
- **Supply Input:** 24VDC (+/- 10%) / 5 Watts (Max)
- **Data Communications:** Copper CAN (4), Fibre CAN (1 shared with Copper CAN), RS-422 (3), RS-232 (2)
- **Operating Temperature:** -20 to 70 C
- **Inputs:** 16 x Digital Inputs (24VDC)
- **Outputs:** 1 x C-Form Relay (110VAC / 8 A)
- **Connector 1:** Obelix A2 (24VDC Input + CAN Bus A)
- **Connector 2:** Ethernet M12(WAN)
- **Connector 3:** Ethernet M12 (LAN)
- **Connector 4:** Obelix Data A68 (CAN B,C,D, RS422, RS232)
- **Connector 5:** Obelix A69 (Digital Inputs, Relay Output)

CONNECTOR A2

PIN	Connector A2 Burndy Female 8 Way	Signal
A2-A	Supply Input	24VDC Supply Input
A2-B	Supply Input	0VDC Supply Input
A2-C	CAN A (Positive)	Communications
A2-D	CAN A (Positive)	Communications
A2-E	CAN A (Negative)	Communications
A2-F	CAN A (Negative)	Communications
A2-G	Termination Link 1 - 1	Termination Link Input
A2-H	Termination Link 1 - 2	Termination Link Input



L0ZU0101 Obelix Processor Module Telemetry and Automation

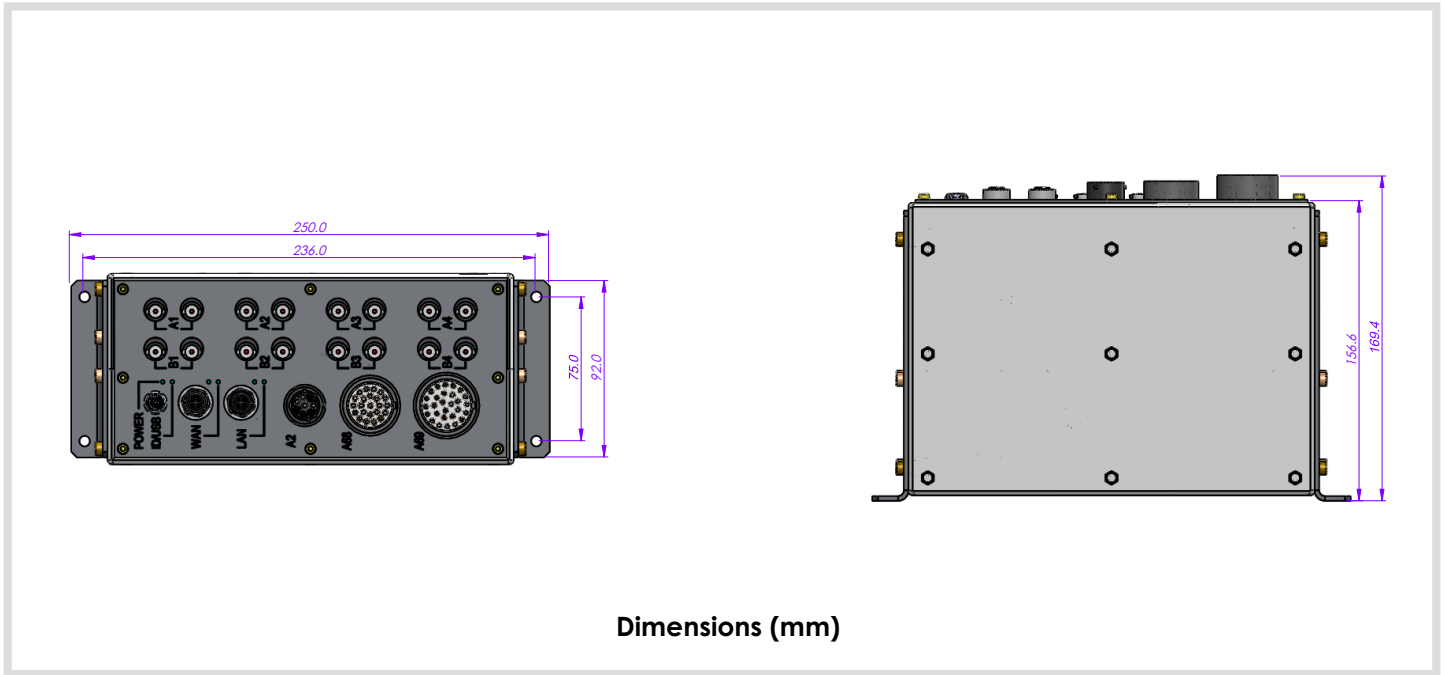

Dimensions (mm)

CONNECTOR A68

No.	Connector A68 23 (32) Burndy Female PIN	Name
1	A	CANH1
2	B	CANL1
3	C	CANH2
4	D	CANL2
5	E	CANH3
6	F	CANL3
7	G	0VDC
8	H	RXA-
9	J	RXA+
10	K	TXA-
11	L	TXA+
12	M	RXB- /CTSB
13	N	RXB+ /RXB
14	P	TXB- / TXB
15	R	TXB+ /RTSB
16	S	0VDC
17	T	RXC-
18	U	RXC+
19	V	TXC-
20	W	TXC+
21	X	RXD
22	Y	TXD
23	Z	0VDC



LOZU0101 Obelix Processor Module Telemetry and Automation

CONNECTOR A69

No.	Connector A69 28 (41) Burndy Female PIN	Name
1	A	DGI-1
2	B	DGI-2
3	C	DGI-3
4	D	DGI-4
5	E	DGI-5
6	F	DGI-6
7	G	DGI-7
8	H	DGI-8
9	J	DGI-9
10	K	DGI-10
11	L	DGI-11
12	M	DGI-12
13	N	DGI-13
14	P	DGI-14
15	R	DGI-15
16	S	DGI-16
17	T	0VDC
18	U	CAN 1-L1
19	V	CAN 1-L2
20	W	COLDFIRE UART RX-
21	X	COLDFIRE UART RX+
22	Y	COLDFIRE UART TX-
23	Z	COLDFIRE UART TX+
24	a	CAN 2-L1
25	b	CAN 2-L2
26	c	RELAY IN
27	d	RELAY NC
28	e	RELAY NO



Fibre Optic Patch ST -ST Multi-mode

Part Number	Description
H0LW0401	Fibre Optic Patch ST-ST Multi-mode

Specifications

- **Product Type:** Pre-manufactured cable assembly
- **Construction:** Fibre-optic with ST terminations
- **Connector 1 :** Fibre ST Connector (2 connectors)
- **Connector 2:** Fibre ST Connector (2 connectors)
- **Conductors:** 2
- **Cable Length:** 0.8 metres
- **Pin Type:** ST Fibre Plugs
- **Conductor Type:** Multi-mode Fibre-optic
- **Insulation Rating:** N/A
- **Temperature Rating:** -40 to 85 C