

L11V0101 AC VFD System Filter with Common Mode Choke 1140V

The L11V0101 EMC filter is designed for high noise environment typical of remote electrically powered mining equipment.

Input EMC filter featuring an integrated Common Mode Choke and high capacitance components minimise conducted, Radio-Frequency interference voltage reducing nuisance power line trips from remote power monitor relays.

The L11V family also features an integrated Earth Switching relay to defeat touch potentials that can exist on power line networks rendering protected equipment safe.

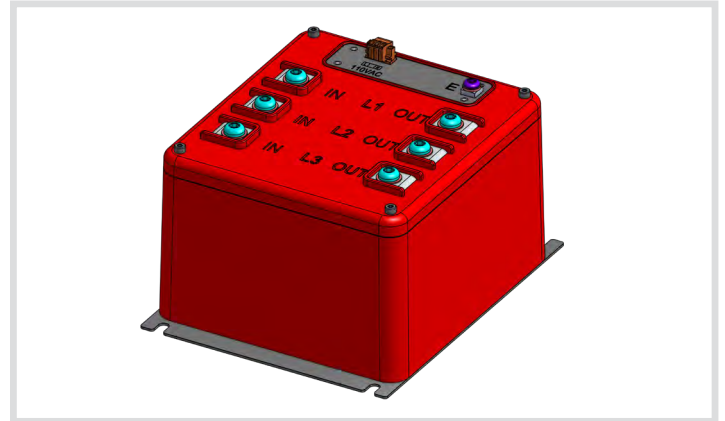

- L11V0101 EMC filter reduces the EMC interference and connects on the power input side to cut off or isolate the interference channel between power network and VFD.
- Suppress the harmonic or surge from power network to resolve nuisance malfunction introduced by variable frequency drive.
- L11V0101 EMC filter must be installed upstream on mains side of the variable frequency drive.
- Integrated earth switching relay can be used for delayed earth connection to avoid inrush charging current
- Integrated Common Mode Choke can resolve nuisance malfunction of distribution boxes (like Ampcontrol IPD etc)

Mounting hole position and screws required

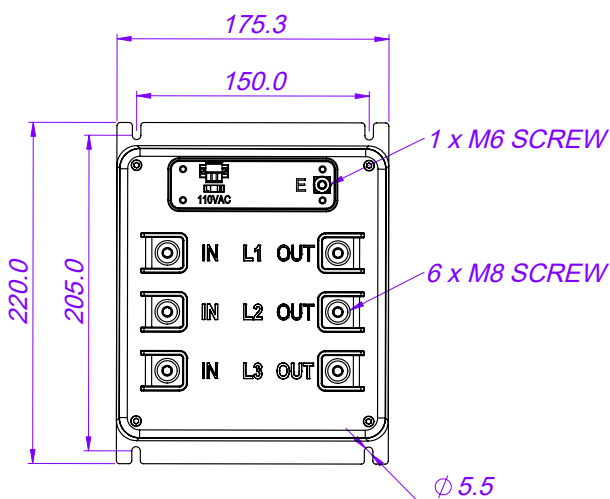

Typical Application

- Continuous Miners
- Continuous Haulage
- Long Wall Shearers
- Mobile Bolters
- Mobile Roof Supports
- Remote Control Scoops
- Remote Control Loaders
- Shuttle Cars
- Feeder Breakers

L11V0101 AC VFD System Filter with Common Mode Choke 1140V

L11V Pilot line noise Suppression

Typical Motor Drive in operation without any filter;



Typical Motor Drive in operation with Pempek L11V filter;



Touch Potential with delayed earthing;



The PEMPEK L11V filter successfully mitigates the noise on motor drive pilot line and the PEMPEK L11V Filter earth switching mechanism decreases the touch potential from a dangerous 170V to a safe 35V.

L11V0101 AC VFD System Filter with Common Mode Choke 1140V

Specifications

- Rated Voltage 1140V
- Rated Current 400A
- Rated frequency 50/60 Hz
- Capacitance 3.65uF and 1mH

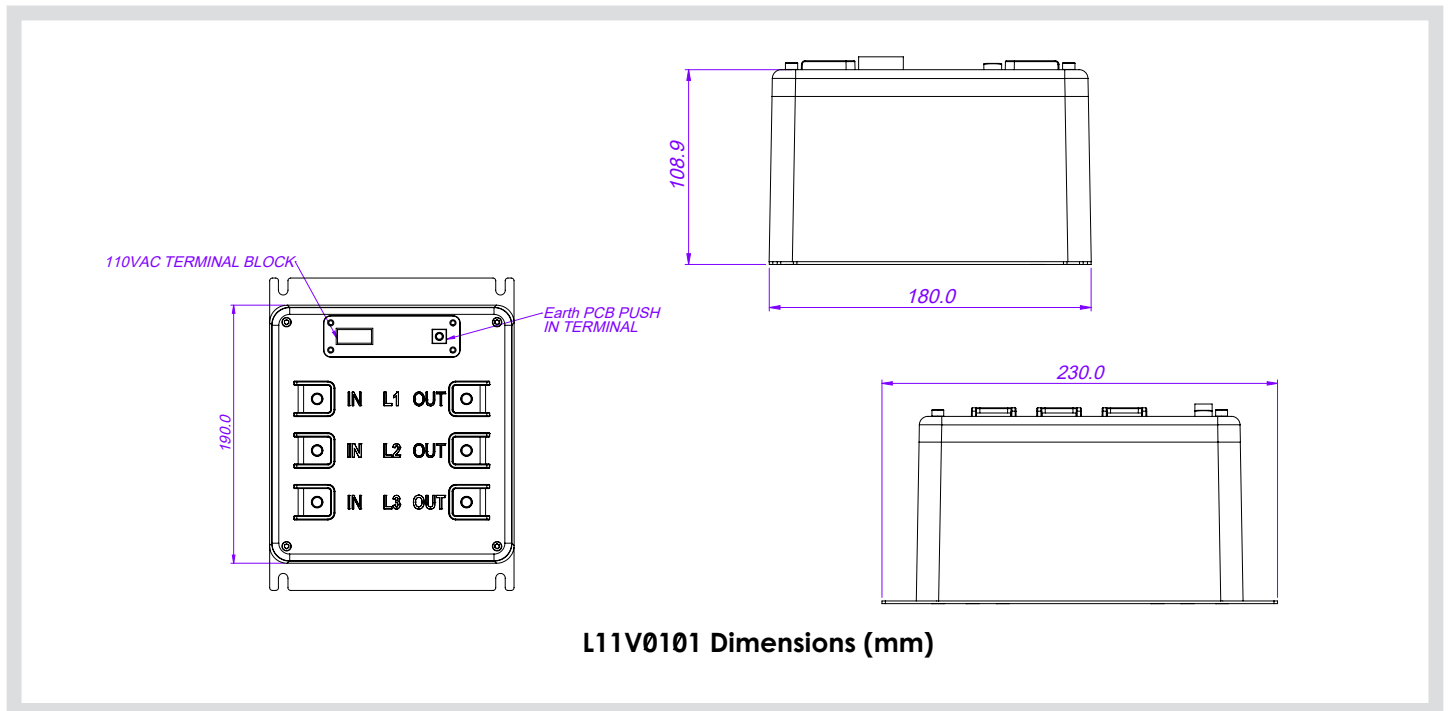

Circuit

