

L12F0101 UberMate 3.0 CAN Motor Protection Module 4 x 110VAC

A compact, highly integrated control and protection device for 3-phase induction motors. It controls one Forward Motor Contactor – or Forward/Revers Contactor Pair – for direct-on-line (DOL) motor starting. Onboard inputs monitor motor current, temperature and contactor status. A host PLC can rely on built-in motor protection – or disable this protection to use the device as a remote I/O.

Contactor Control

- Full control and monitoring provided by CANopen field bus
- Controls one [ON/OFF] or two [FORWARD/REVERSE] motor contactors.
- Switching contacts rated to 16 Amperes (make/break 4000 VA)
- Switching contacts support withstand inrush of 80 Amperes.
- Two contacts in series to comply with functional safety requirements.
- All relay outputs are protected by internal hardware watchdog timer.

General Purpose Relay

- Additional auxiliary “C-Form” relay output (for general purpose use or upstream power isolation).

Contactor Status Monitoring

- Four (4) opto-isolated 110VAC digital inputs.
- Used for general purpose or for monitoring contactor auxiliary contact status

Motor Current Monitoring

- True RMS current measurement with range from less than 100mA up to 1600 A. Measurement settling time 100 milliseconds.

Motor Temperature Monitoring

- Three (3) self-powered, 2-wire PT100 inputs.
- Galvanically-isolated (UL 1577: 5000 V RMS for 1 minute).
- Built-in earth leakage resistance measurement.

Motor Protection Options

- Protection is configurable for each protection skill by host PLC control system in real-time
- Give system integrators the flexibility to use built-in protection or custom PLC-managed protection
- Built-in motor protection options:
 - Motor Over Temperature Protection (via PT100 temperature sensors)
 - Jammed Motor Rotor Protection (based on motor current measurement)
 - Thermal Overload Protection (based on inverse-time calculation of motor currents)
 - Phase Imbalance Protection (unequal motor currents in 3-phase system)
 - Phase Rotation Sequence Verification



L12F0101 UberMate 3.0 CAN Motor Protection Module 4 x 110VAC

Control and Monitoring Concept

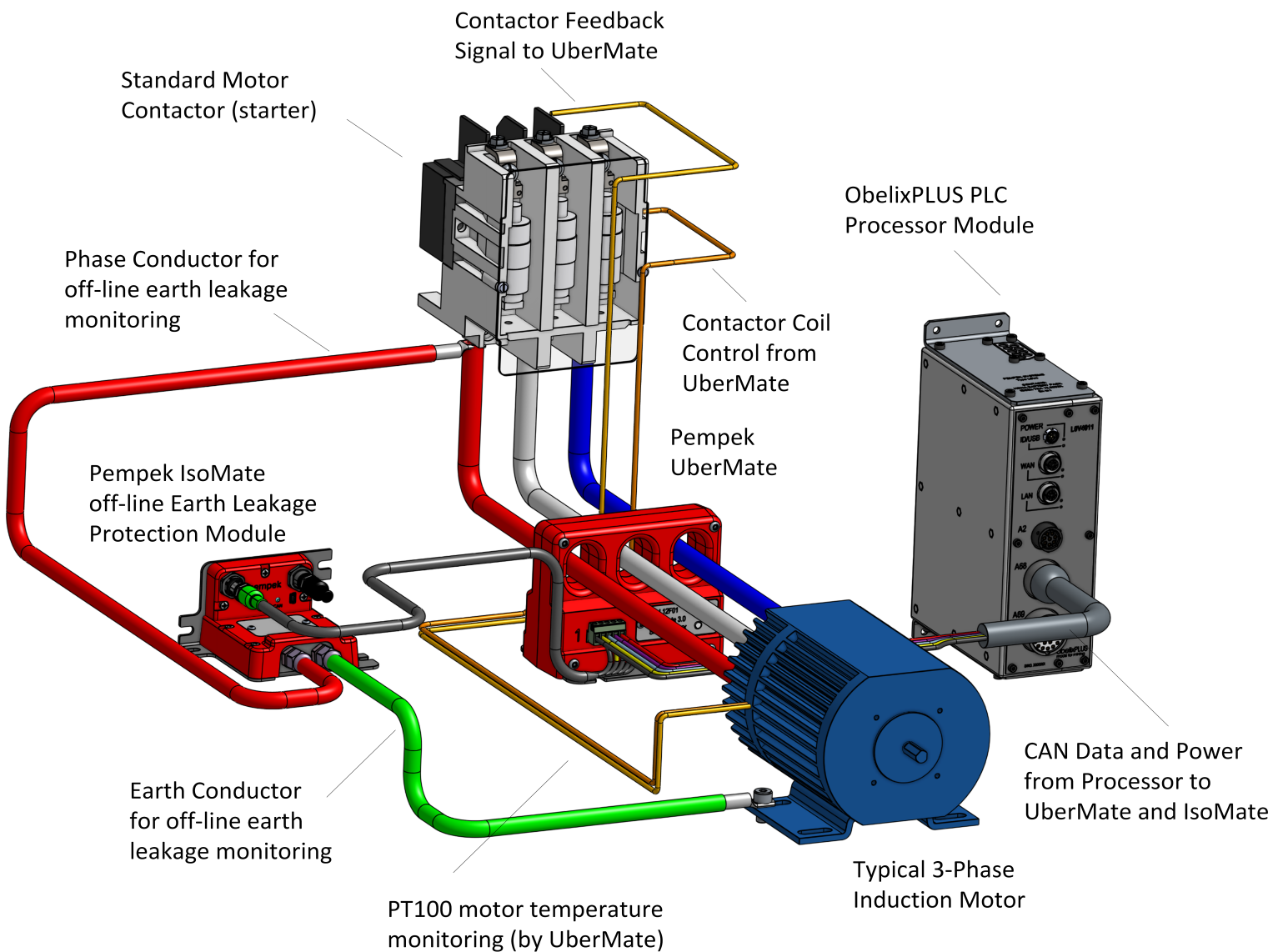

L12F0101 UberMate 3.0 CAN Motor Protection Module 4 x 110VAC

Example Electrical Wiring – Single Motor Forward Control

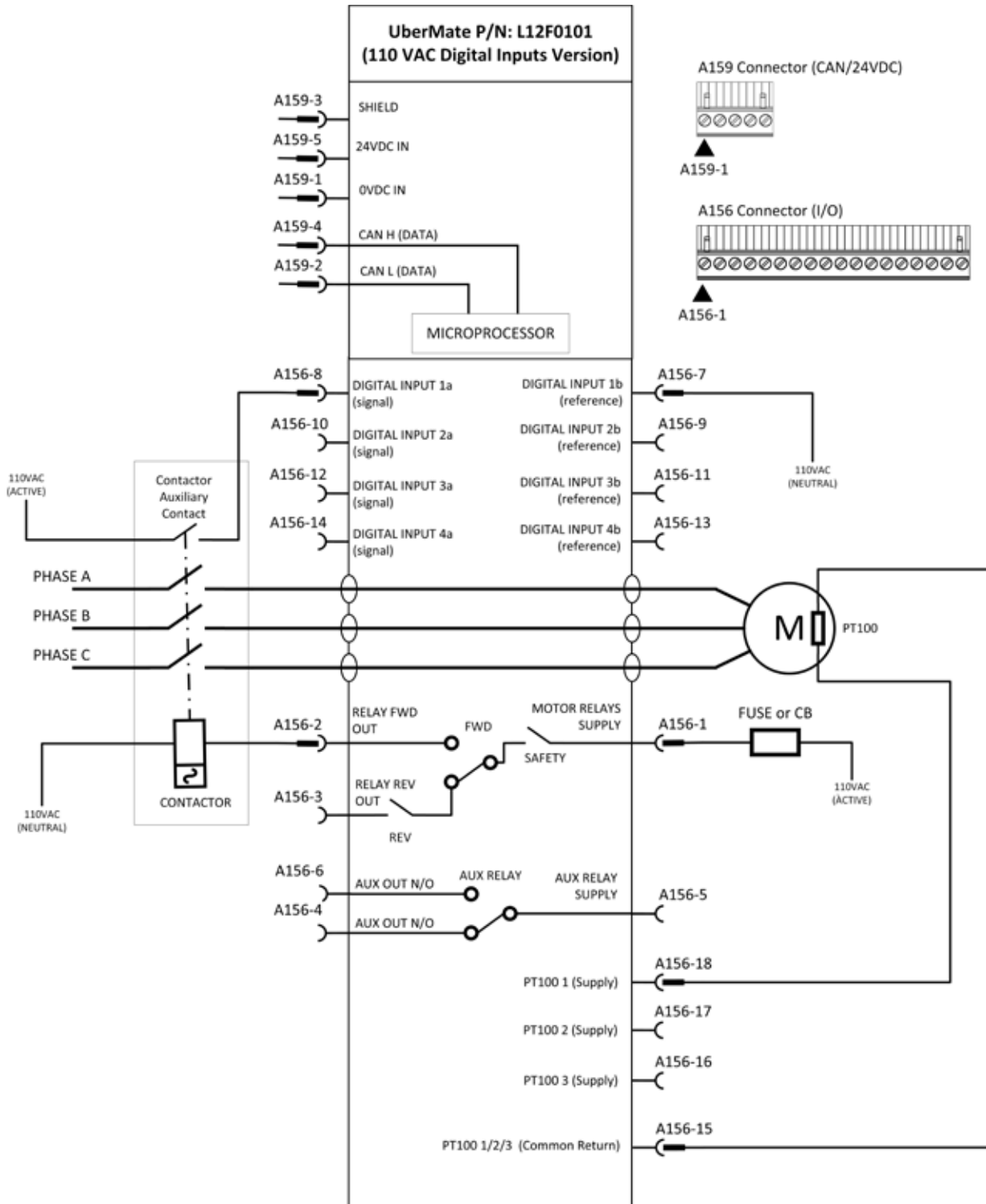

L12F0101 UberMate 3.0 CAN Motor Protection Module 4 x 110VAC

Motor Temperature Protection Options

Example – Monitoring of single PT100 inside motor windings

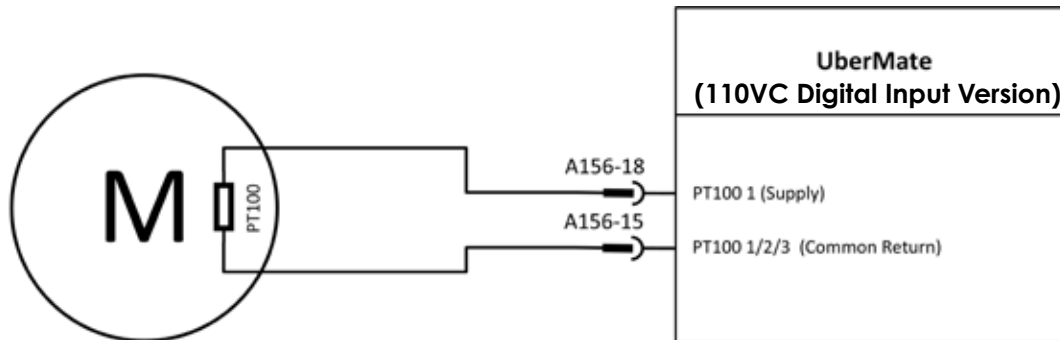

Example – Monitoring of over temperature switch inside motor windings

Install a fixed 100 Ω resistor in series with the switch. Allows UberMate to detect open-circuit event (meaning switch has opened due to high temperature)

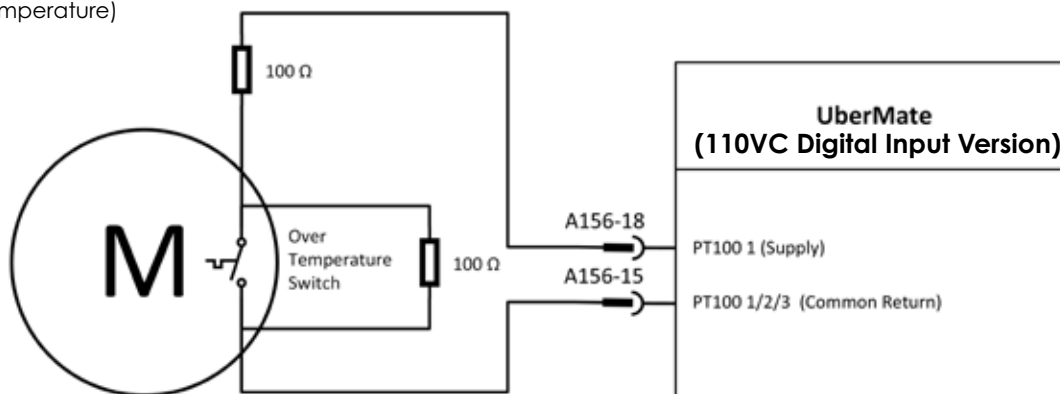

Example – Monitoring full set of three PT100s in the motor windings

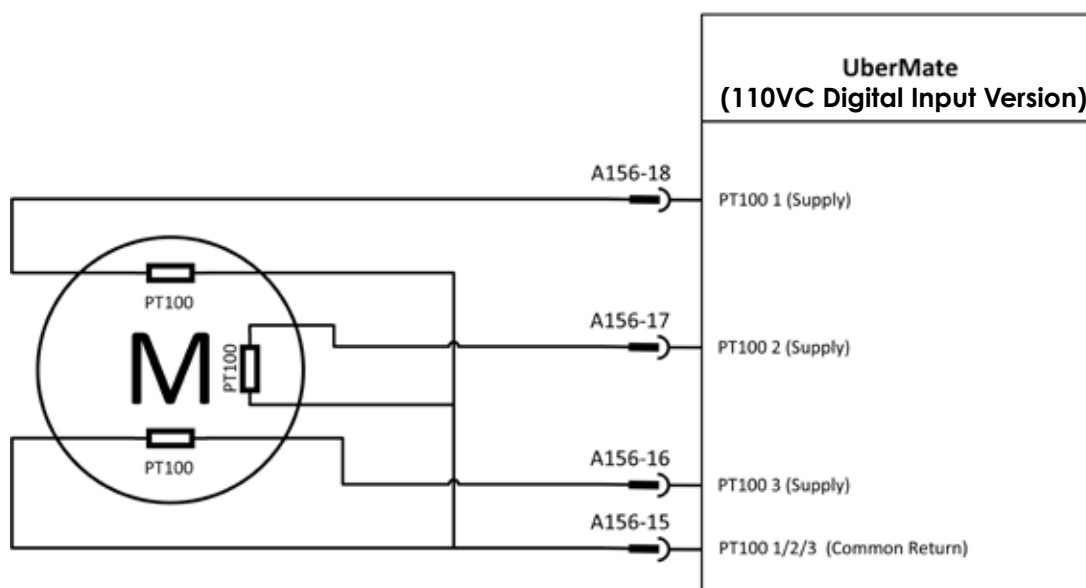

L12F0101 UberMate 3.0 CAN Motor Protection Module 4 x 110VAC

CAN Network Installation – Node ID and Bus Speed Configuration

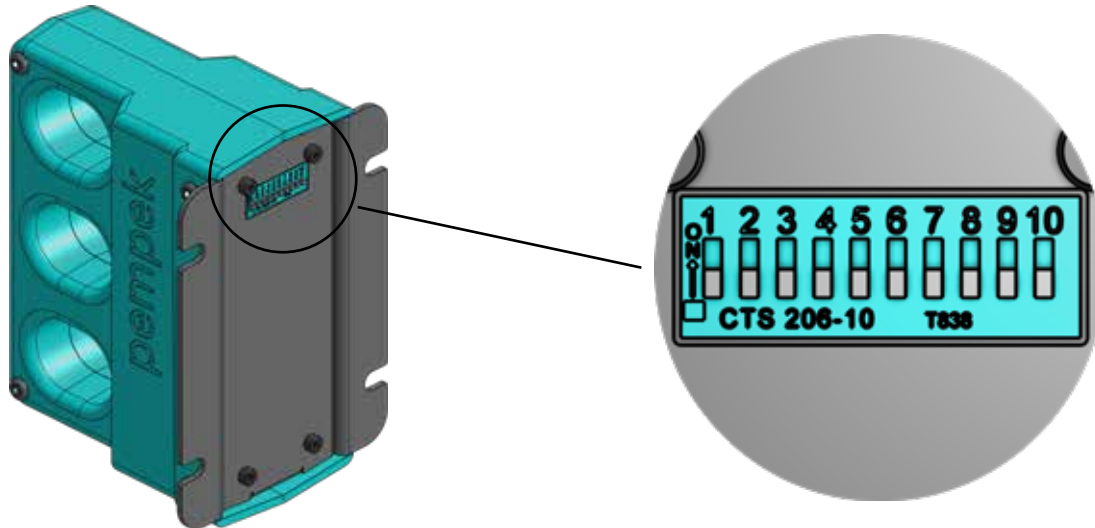

CAN Bus Speed Settings

Important – All devices on the same CAN bus must be set to the same speed. Speed is configured by setting dipswitches 8 thru 10.

Bus Speed	Dip Switch Setting	NODE ID	Dip Switch Setting
Illegal Setting		250 kbps	
Auto Speed Sensing		500 kbps	
50 kbps		1 mbps	
125 kbps			

L12F0101 UberMate 3.0 CAN Motor Protection Module 4 x 110VAC





CAN Bus Unique Node ID (Address) Settings

127 different node IDs are supported – based on dip switch settings (switches 1 thru 7).

IMPORTANT

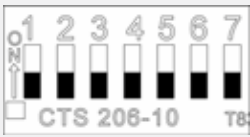
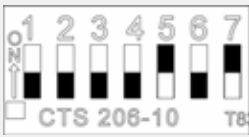
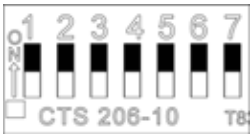
The device has a built-in safety feature that detects when the Node ID (dipswitch settings) have been changed since the device was last used. If the device does detect a change in Node ID setting it will enter CATASTROPHIC ERROR mode and the diagnostic LED will flicker RED/GREEN very rapidly (50 milliseconds RED / 50 milliseconds GREEN).

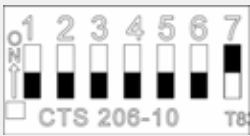
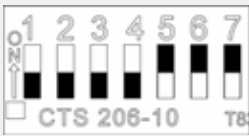
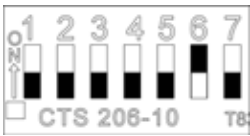
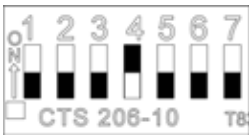
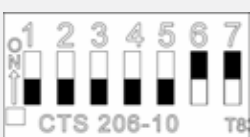
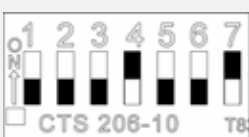
If the host PLC wants to accept the change in Node ID for that unit – it must send a special command to clear the catastrophic error and confirm the new Node ID.

NODE ID	Dip Switch Setting	NODE ID	Dip Switch Setting
LSS Mode*		5	
127 (Maximum)		6	
1		7	
2		8	
3		9	
4		10	

* WARNING - LSS Mode shall be used with caution to avoid incorrect node allocation that may result in incorrect motor being started from host

L12F0101 UberMate 3.0 CAN Motor Protection Module 4 x 110VAC

CAN Network Installation – Network Cabling

Example Installation – Four (4) UberMates and One (1) Host PLC

- Power and CAN cables daisy chained between modules
- Each node on the bus shall have a unique node ID
- It is important that the CAN network have termination resistors at each end.
- When setup correctly; resistance between CAN H and CAN L should be approximately 60 Ohms.

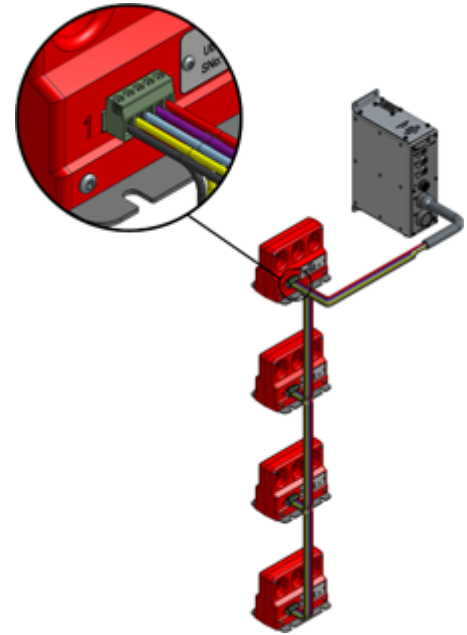
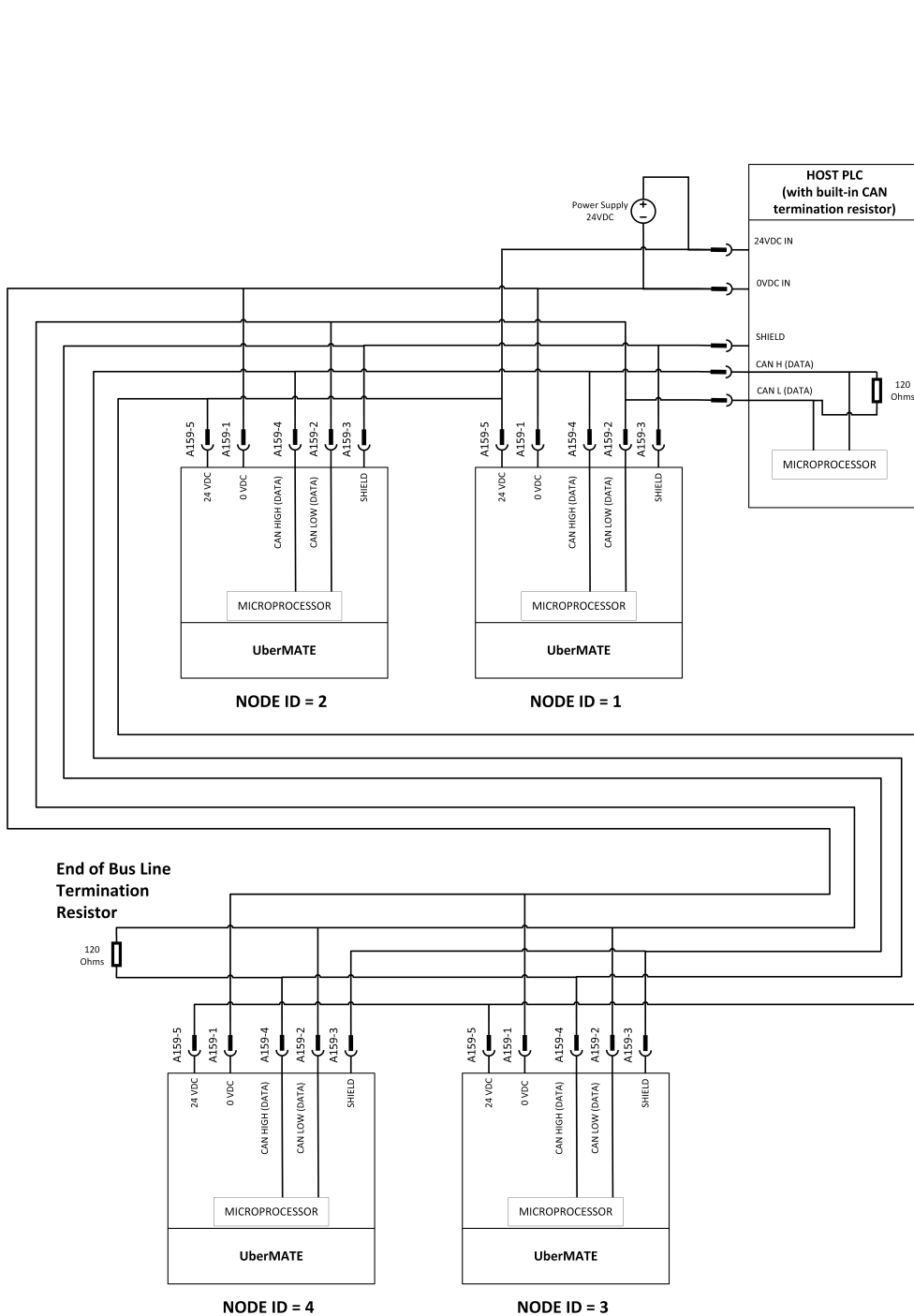

L12F0101 UberMate 3.0 CAN Motor Protection Module 4 x 110VAC

UberMate 3.0 | Diagnostic LED

LED Behavior	Diagnostic Meaning	CANopen State
OFF	No power to device	
GREEN (Continuous)	Device is healthy and communicating with host.	
RED (Continuous)	CAN Bus Off Error. Can only be cleared by cycling the power	OPERATIONAL
GREEN (Blinking) 200 ms On / 200 ms Off	Device is waiting for network master (PLC) to send start command.	
GREEN (Single Flashing) 200 ms On / 1 second Off	Device was stopped by network master (PLC).	PRE-OPERATIONAL
RED (Blinking) 200 ms On / 200 ms Off	Device configuration is not valid.	STOPPED
RED (Single Flashing) 200 ms On / 1 second Off	CAN controller error in the device.	STOPPED
RED (2 Times Flashing) 200 ms On / 200 ms Off / 200 ms On / 1 Second Off	Node guarding or heartbeat error.	STOPPED
RED (3 Times Flashing) 200 ms On / 200 ms Off / 200 ms On / 200 ms Off / 200 ms On / 1 Second Off	Sync message not received within timeout period.	STOPPED
RED (4 Times Flashing) 200 ms On / 200 ms Off / 200 ms On / 200 ms Off / 200 ms On / 200 ms Off / 200 ms On / 1 Second Off	Process data object (PDO) message not received within timeout period.	STOPPED
RED (5 Times Flashing) 200 ms On / 200 ms Off / 200 ms On / 200 ms Off / 200 ms On / 200 ms Off / 200 ms On / 200 ms Off / 200 ms On / 1 Second Off	Fatal Error. Node will remain in OPERATIONAL state (if it was currently in that state). Relay outputs are disabled until error is cleared by the network master (PLC).	PREOPERATIONAL or OPERATIONAL
RED (6 Times Flashing) 200 ms On / 200 ms Off / 200 ms On / 200 ms Off / 200 ms On / 200 ms Off / 200 ms On / 200 ms Off / 200 ms On / 200 ms Off / 200 ms On / 1 Second Off	Critical Error. All control / monitoring disabled. Error can be cleared by network master (PLC) or by cycling the power to the device.	STOPPED
RED GREEN (Flickering) 50 ms GREEN / 50 ms RED	Catastrophic Error or Device is initializing. All control / monitoring disabled. Catastrophic Error can only be cleared by a special command from network master (PLC).	STOPPED

L12F0101 UberMate 3.0 CAN Motor Protection Module 4 x 110VAC

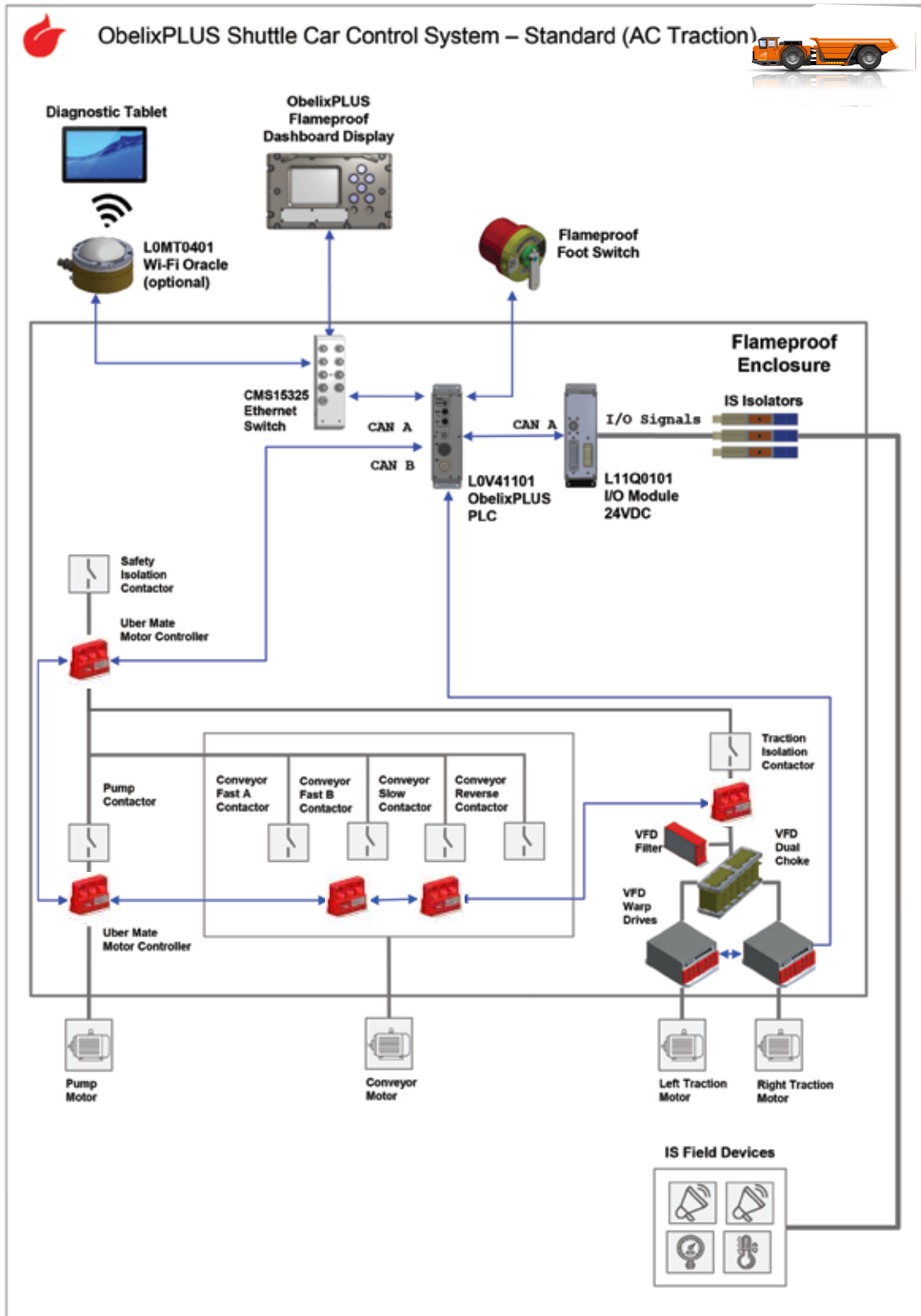

L12F0101 UberMate 3.0 CAN Motor Protection Module 4 x 110VAC

Mechanical

Housing ABS Plastic	Plated mild steel, 2mm
Dimensions	Volume (W) 140mm x (H) 110mm x (D) x 95mm
Dimensions	Mounting (W) 80mm x (D) 80mm
Conductor Aperture	25mm x 35mm (A comfortable fit for lugged 120mm ²)
Mass	0.7kg (without connector)
Installation	4 x M6 x 12mm + Pressure Washer Recommended Max. Torque = 9Nm

Environmental

IP Rating	N/A
Temperature Rating	Component -40°C +85°C
Temperature Rating	Ambient Operating -35°C +75°C

Supply / Interface

Voltage / Power	18..30 VDC / < 5W
Polarity Safe	YES
Network	CAN 2.0B, CANOpen Compliant

Inputs

Current	3 x True RMS Rogowski Coils – 1..1600A @ 1% Linear Scale (10000A peak)
Digital	4 Inputs (110VAC - Part Number: L12F0101) or (24VDC – Part Number: L12F0201) or (L12F0301 2 x Inputs (110 VAC) 2 x Inputs (24 VDC)
RTD	3 x PT100 Line Fault Protected – isolation UL 1577: 5000 V RM

Outputs

Relays	2 x Contact(s) Voltage Free – Forward / Reverse Configuration
Relays	1 x Contact(s) Voltage Free – Auxiliary
All contacts are	240V / 16A rated, make/break 4000VA, inrush 80Amps

Test Standards:

Climatic Test	EN 60068-2-30 (Damp heat, non-condensing)
Mechanical Stability	EN 60068-2-6 (Vibration)
Immunity to Interfering Fields	EN 61000-6-2 2005
Interference Emission	EN 61000-6-4 2007

Dimensions (mm)

